

Tests of Lorentz and CPT Violation with Neutrinos



Find us on Facebook,
"Institute of Physics Astroparticle Physics"
<https://www.facebook.com/IOPAPP>

Teppei Katori
Queen Mary University of London
High Energy Physics seminar, Univ. Oxford, Oxford, UK, Mar. 1, 2016



Tests of Lorentz and CPT Violation with Neutrinos

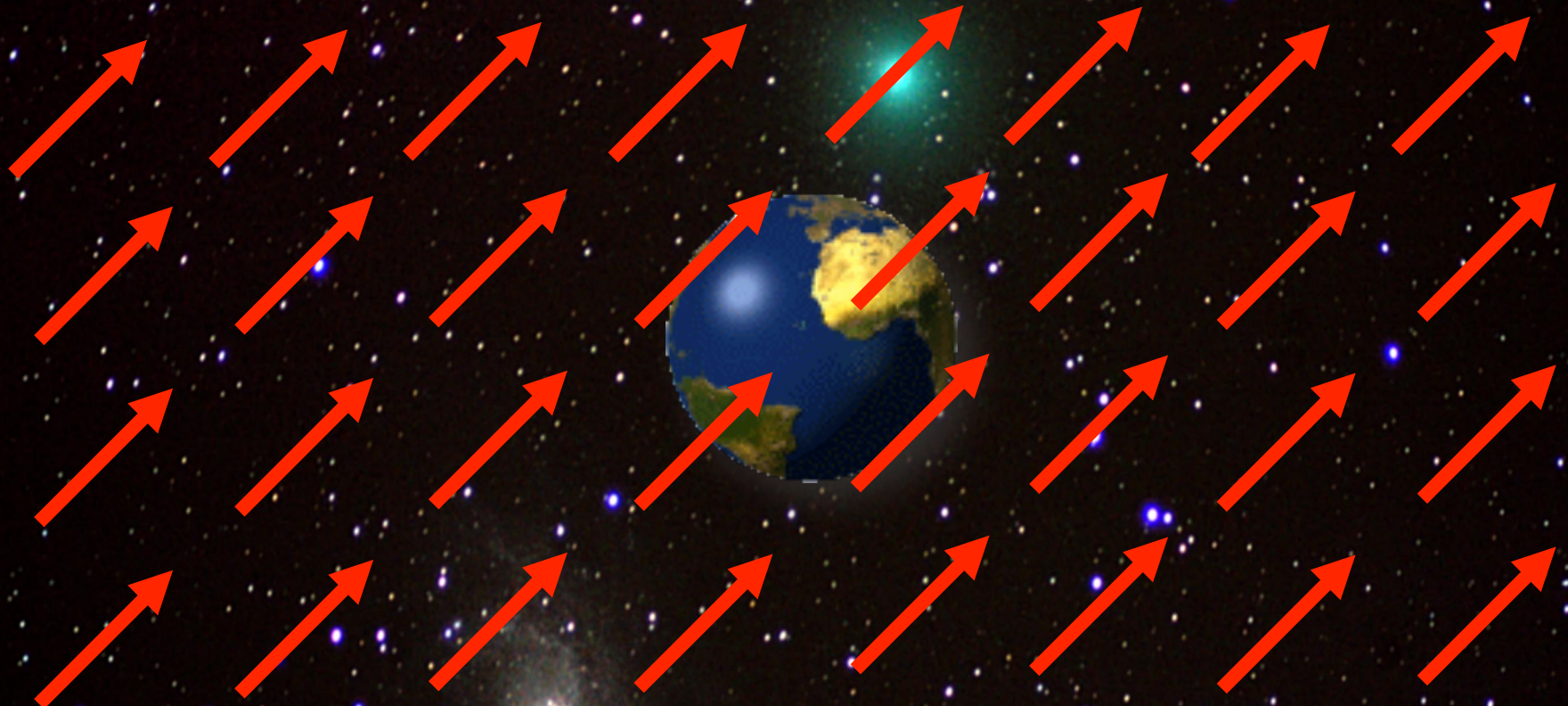

Teppei Katori
Queen Mary University of London
High Energy Physics seminar, Univ. Oxford, Oxford, UK, Mar. 1, 2016



Tests of Lorentz and CPT Violation with Neutrinos

outline

1. Spontaneous Lorentz symmetry breaking
2. What is Lorentz and CPT violation?
3. Modern test of Lorentz violation
4. Lorentz violating neutrino oscillations
5. Test for Lorentz violation with MiniBooNE data
6. Test for Lorentz violation with Double Chooz data
7. Extra-terrestrial ultra-high-energy neutrinos
8. Conclusion

Teppei Katori

Queen Mary University of London

High Energy Physics seminar, Univ. Oxford, Oxford, UK, Mar. 1, 2016



- 1. Spontaneous Lorentz symmetry breaking**
2. What is Lorentz and CPT violation?
3. Modern test of Lorentz violation
4. Lorentz violating neutrino oscillation
5. Test for Lorentz violation with MiniBooNE data
6. Test for Lorentz violation with Double Chooz data
7. Extra-terrestrial ultra-high-energy neutrinos
8. Conclusion

1. Spontaneous Lorentz symmetry breaking (SLSB)

Every fundamental symmetry needs to be tested, including Lorentz symmetry.

After the recognition of theoretical processes that create Lorentz violation, testing Lorentz invariance becomes very exciting

Lorentz and CPT violation has been shown to occur in Planck scale theories, including:

- string theory
- noncommutative field theory
- quantum loop gravity
- extra dimensions
- etc

However, it is very difficult to build a self-consistent theory with Lorentz violation...

1. Spontaneous Lorentz symmetry breaking (SLSB)

Every fundamental symmetry needs to be tested, including Lorentz symmetry.

After the recognition of theoretical processes that create Lorentz violation, testing Lorentz invariance becomes very exciting

Lorentz and CPT violation has been shown to occur in Planck scale theories, including:

- string theory
- noncommutative field theory
- quantum loop gravity
- extra dimensions
- etc

However, it is very difficult to build a self-consistent theory with Lorentz violation...

Spontaneous
Symmetry Breaking
(SSB)!



Y. Nambu
(Nobel prize winner 2008),
picture from CPT04 at
Bloomington, IN

1. Spontaneous Lorentz symmetry breaking (SLSB)

$$\text{vacuum Lagrangian for fermion } \mathcal{L} = i\bar{\Psi}\gamma_{\mu}\partial^{\mu}\Psi$$

e.g.) SSB of scalar field in Standard Model (SM)
- If the scalar field has Mexican hat potential

$$L = \frac{1}{2}(\partial_{\mu}\varphi)^2 - \frac{1}{2}\mu^2(\varphi^*\varphi) - \frac{1}{4}\lambda(\varphi^*\varphi)^2$$

$$M(\varphi) = \mu^2 < 0$$

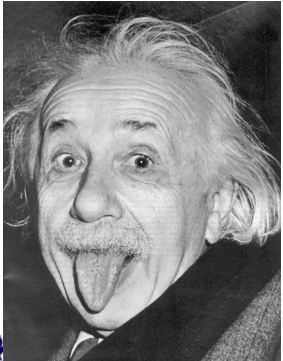
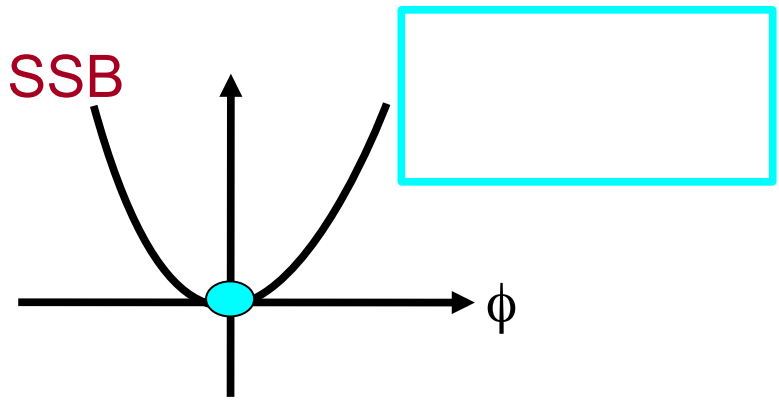

1. Spontaneous Lorentz symmetry breaking (SLSB)

$$\text{vacuum Lagrangian for fermion } \mathcal{L} = i\bar{\Psi}\gamma_{\mu}\partial^{\mu}\Psi - m\bar{\Psi}\Psi$$

e.g.) SSB of scalar field in Standard Model (SM)
- If the scalar field has Mexican hat potential

$$L = \frac{1}{2}(\partial_{\mu}\varphi)^2 - \frac{1}{2}\mu^2(\varphi^*\varphi) - \frac{1}{4}\lambda(\varphi^*\varphi)^2$$

$$M(\varphi) = \mu^2 < 0$$

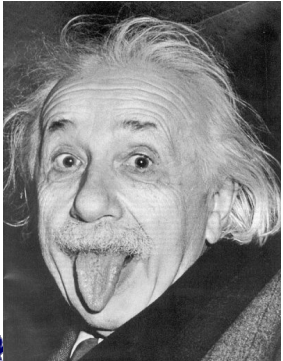
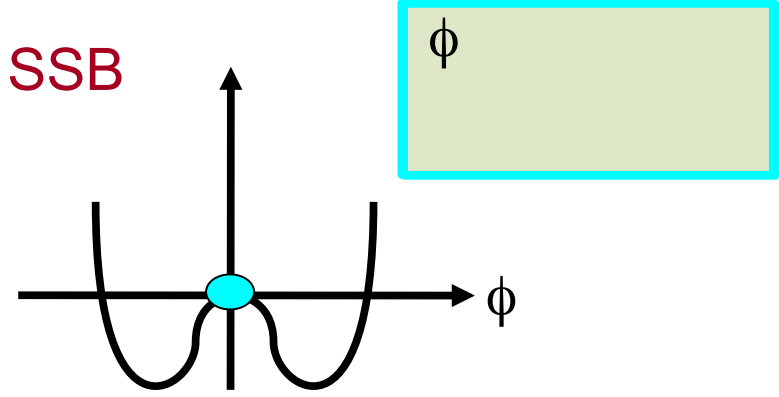

Particle acquires mass term!

1. Spontaneous Lorentz symmetry breaking (SLSB)

vacuum Lagrangian for fermion $L = i\bar{\Psi}\gamma_\mu\partial^\mu\Psi - m\bar{\Psi}\Psi$

e.g.) SSB of scalar field in Standard Model (SM)

- If the scalar field has Mexican hat potential

$$L = \frac{1}{2}(\partial_\mu\varphi)^2 - \frac{1}{2}\mu^2(\varphi^*\varphi) - \frac{1}{4}\lambda(\varphi^*\varphi)^2$$

$$M(\varphi) = \mu^2 < 0$$

e.g.) SLSB in string field theory

- There are many Lorentz vector fields

- If any of vector field has Mexican hat potential

$$M(a^\mu) = \mu^2 < 0$$

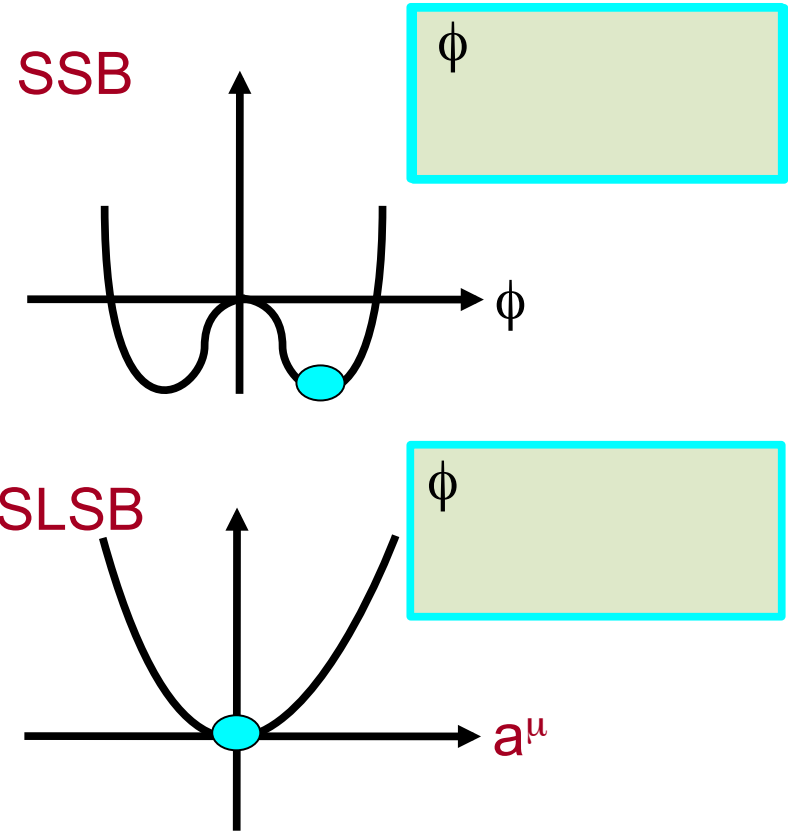
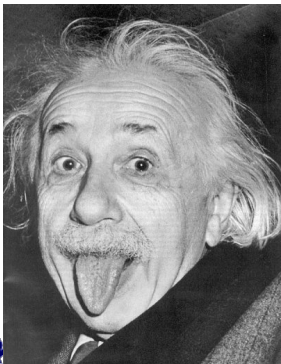

1. Spontaneous Lorentz symmetry breaking (SLSB)

vacuum Lagrangian for fermion $L = i\bar{\Psi}\gamma_\mu\partial^\mu\Psi - m\bar{\Psi}\Psi + \bar{\Psi}\gamma_\mu a^\mu\Psi$

e.g.) SSB of scalar field in Standard Model (SM)

- If the scalar field has Mexican hat potential

$$L = \frac{1}{2}(\partial_\mu\varphi)^2 - \frac{1}{2}\mu^2(\varphi^*\varphi) - \frac{1}{4}\lambda(\varphi^*\varphi)^2$$

$$M(\varphi) = \mu^2 < 0$$

e.g.) SLSB in string field theory

- There are many Lorentz vector fields

- If any of vector field has Mexican hat potential

$$M(a^\mu) = \mu^2 < 0$$

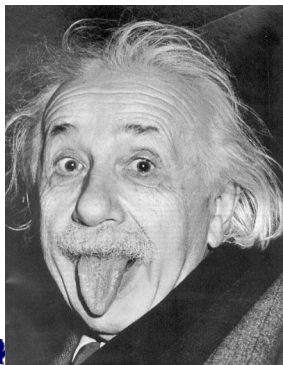

Lorentz symmetry
is spontaneously
broken!

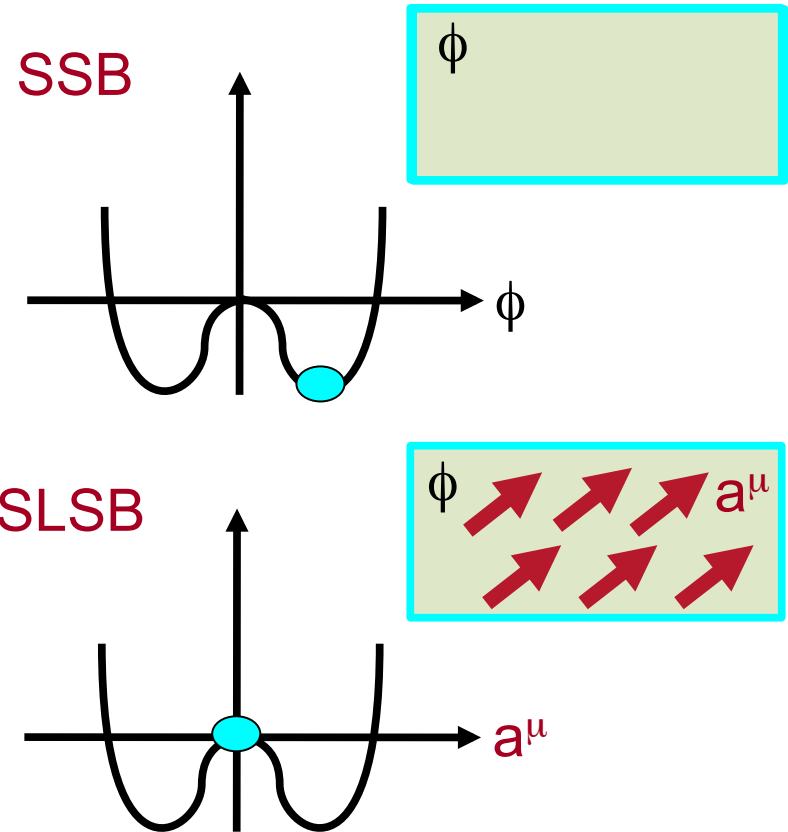

1. Spontaneous Lorentz symmetry breaking

Test of Lorentz violation is to find the coupling of these background fields and ordinary fields (electrons, muons, neutrinos, etc); then **the physical quantities may depend on the rotation of the earth (sidereal time dependence).**

vacuum Lagrangian for fermion

$$L = i\bar{\Psi}\gamma_{\mu}\partial^{\mu}\Psi - m\bar{\Psi}\Psi + \bar{\Psi}\gamma_{\mu}a^{\mu}\Psi + \bar{\Psi}\gamma_{\mu}c^{\mu\nu}\partial_{\nu}\Psi \dots$$

background fields of the universe



Scientific American (Sept. 2004)

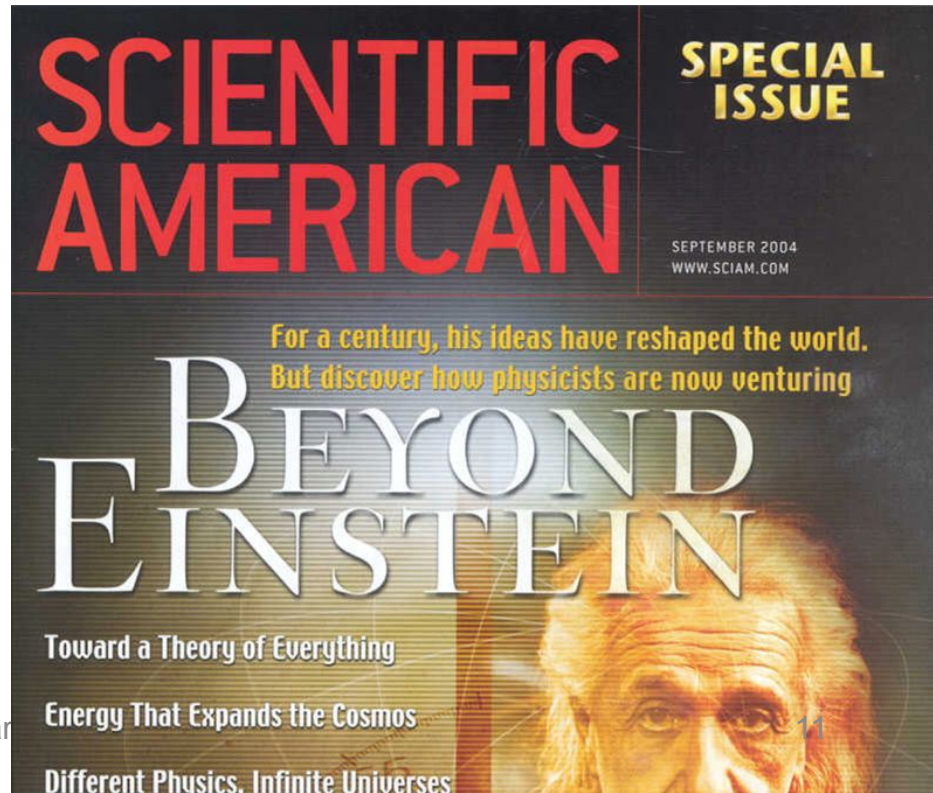
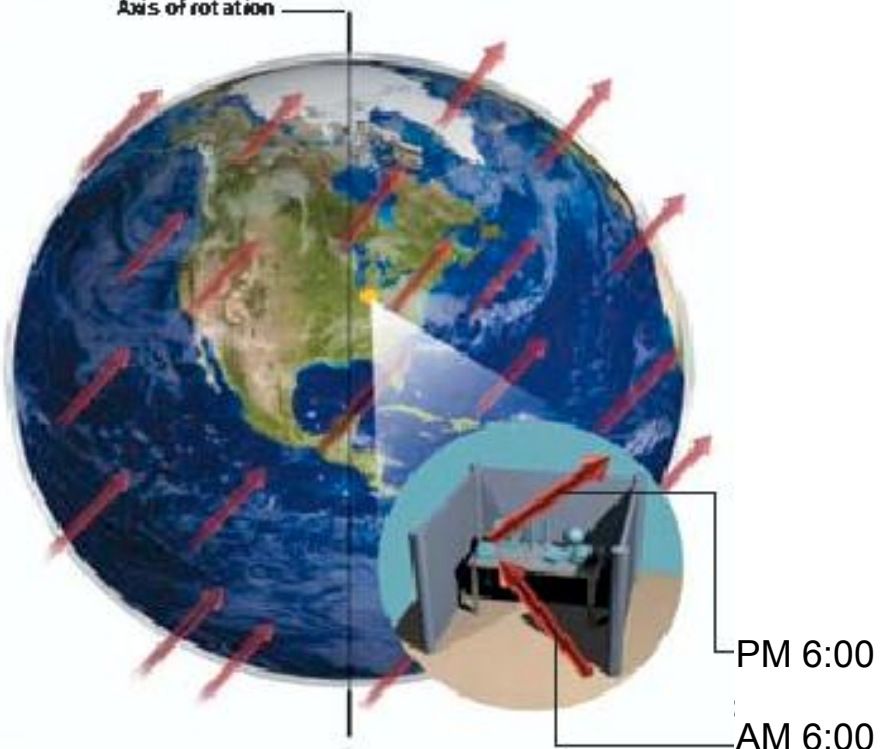

1. Spontaneous Lorentz symmetry breaking

Test of Lorentz violation is to find the coupling of these background fields and ordinary fields (electrons, muons, neutrinos, etc); then **the physical quantities may depend on the rotation of the earth (sidereal time dependence)**.

vacuum Lagrangian for fermion

$$L = i\bar{\Psi}\gamma_{\mu}\partial^{\mu}\Psi - m\bar{\Psi}\Psi + \bar{\Psi}\gamma_{\mu}a^{\mu}\Psi + \bar{\Psi}\gamma_{\mu}c^{\mu\nu}\partial_{\nu}\Psi \dots$$

background fields of the universe

Sidereal time dependence

The smoking gun of Lorentz violation is the **sidereal time dependence** of the observables.

Solar time: 24h 00m 00.0s
sidereal time: 23h 56m 04.1s

Sidereal time dependent physics is often smeared out in solar time distribution
→ Maybe we have some evidence of Lorentz violation but we just didn't notice?!

Target scale

Since it is Planck scale physics, either $>10^{19}\text{GeV}$ or $<10^{-19}\text{GeV}$ is the interesting region.
 $>10^{19}\text{GeV}$ is not possible (LHC is 10^4GeV), but $<10^{-19}\text{GeV}$ is possible.

1. Spontaneous Lorentz symmetry breaking
2. What is Lorentz and CPT violation?
3. Modern test of Lorentz violation
4. Lorentz violating neutrino oscillation
5. Test for Lorentz violation with MiniBooNE data
6. Test for Lorentz violation with Double Chooz data
7. Extra-terrestrial ultra-high energy neutrinos
8. Conclusion

2. What is Lorentz violation?

$$\bar{\Psi}(x)\gamma_{\mu}a^{\mu}\Psi(x)$$

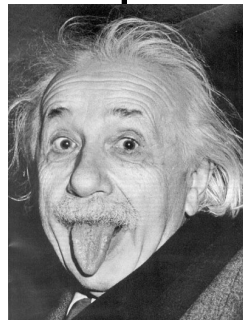
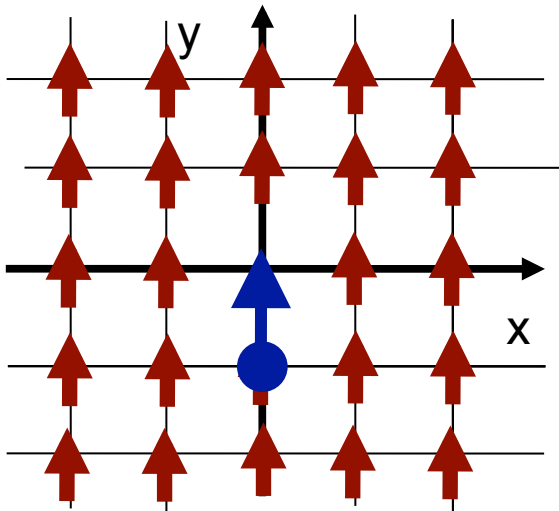

2. What is Lorentz violation?

$$\bar{\Psi}(x)\gamma_{\mu}a^{\mu}\Psi(x)$$

hypothetical background vector field

moving particle

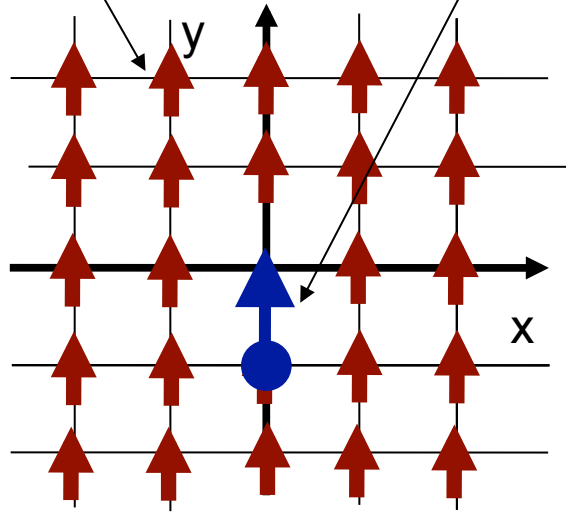

Einstein (observer)

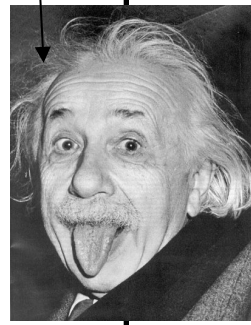

2. What is Lorentz violation?

Under the **particle** Lorentz transformation:

$$U \bar{\Psi}(x) \gamma_{\mu} a^{\mu} \Psi(x) U^{-1}$$

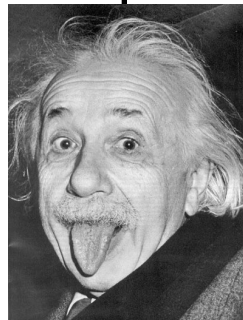
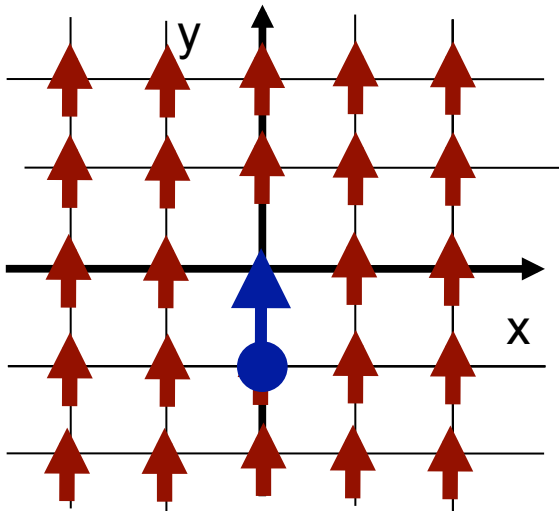

2. What is Lorentz violation?

Under the **particle** Lorentz transformation:

$$\bar{\Psi}(x)\gamma_{\mu}a^{\mu}\Psi(x) \rightarrow U[\bar{\Psi}(x)\gamma_{\mu}a^{\mu}\Psi(x)]U^{-1}$$
$$\neq \bar{\Psi}(\Lambda x)\gamma_{\mu}a^{\mu}\Psi(\Lambda x)$$

Lorentz violation is observable when a particle is moving in the fixed coordinate space

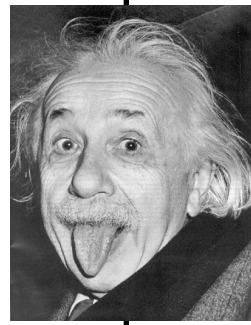
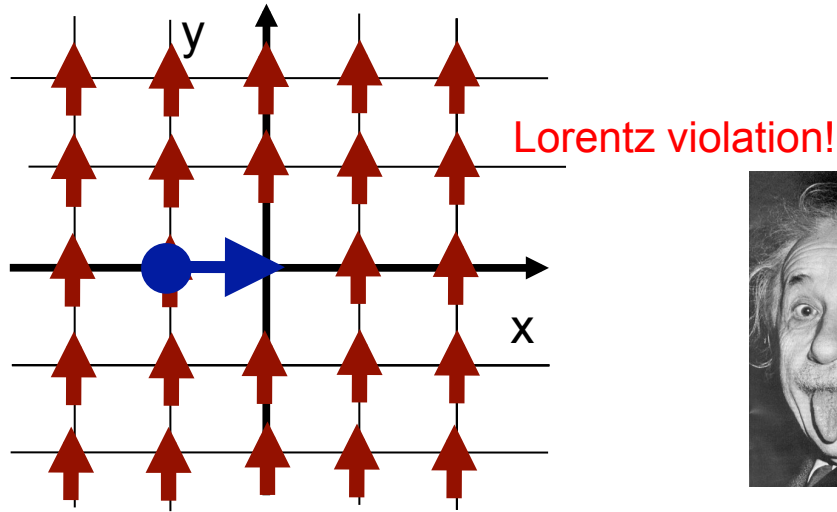

2. What is Lorentz violation?

Under the **particle** Lorentz transformation:

$$\bar{\Psi}(x)\gamma_{\mu}a^{\mu}\Psi(x) \rightarrow U[\bar{\Psi}(x)\gamma_{\mu}a^{\mu}\Psi(x)]U^{-1}$$

$$\neq \bar{\Psi}(\Lambda x)\gamma_{\mu}a^{\mu}\Psi(\Lambda x)$$

Lorentz violation is observable when a particle is moving in the fixed coordinate space

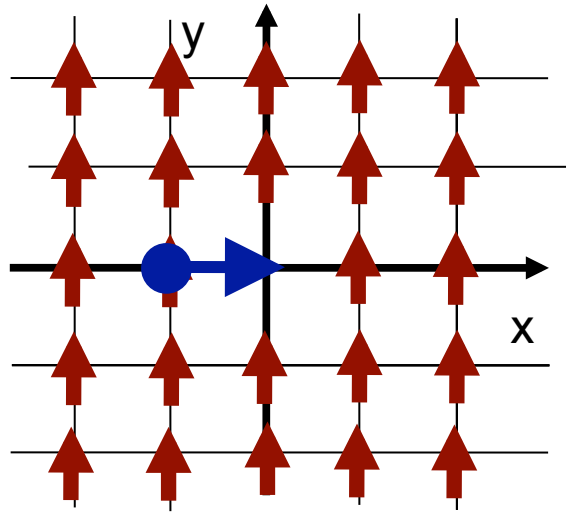

Under the **observer** Lorentz transformation:

$$\bar{\Psi}(x)\gamma_{\mu}a^{\mu}\Psi(x)$$

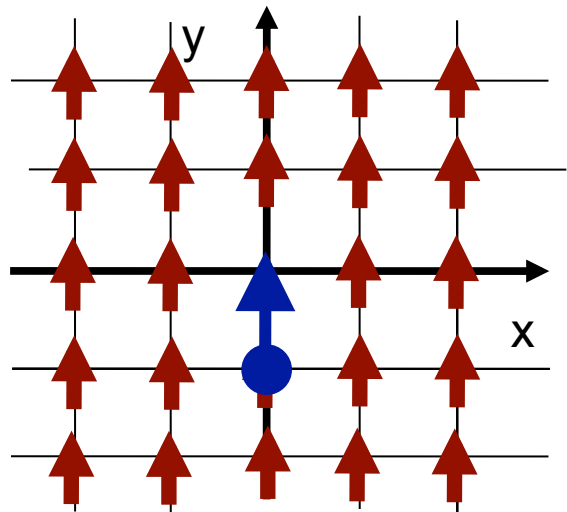
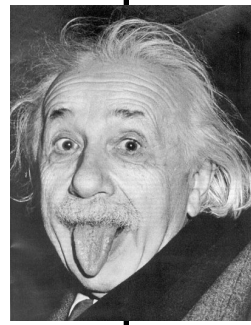

2. What is Lorentz violation?

Under the **particle** Lorentz transformation:

$$\bar{\Psi}(x)\gamma_{\mu}a^{\mu}\Psi(x) \rightarrow U[\bar{\Psi}(x)\gamma_{\mu}a^{\mu}\Psi(x)]U^{-1}$$

$$\neq \bar{\Psi}(\Lambda x)\gamma_{\mu}a^{\mu}\Psi(\Lambda x)$$

Lorentz violation is observable when a particle is moving in the fixed coordinate space

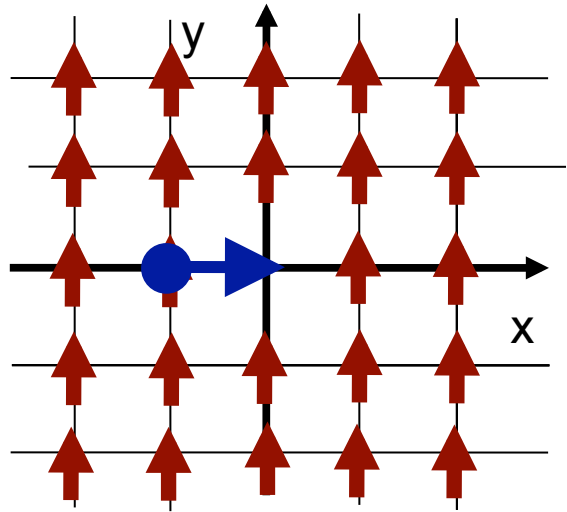

Under the **observer** Lorentz transformation:

$$\bar{\Psi}(x)\gamma_{\mu}a^{\mu}\Psi(x)$$

$$x \rightarrow \Lambda^{-1}x$$

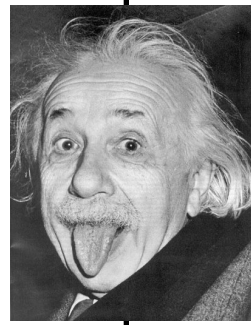
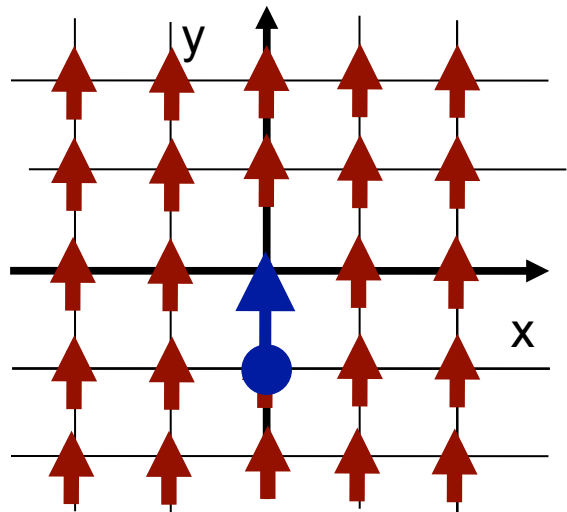

2. What is Lorentz violation?

Under the **particle** Lorentz transformation:

$$\bar{\Psi}(x)\gamma_{\mu}a^{\mu}\Psi(x) \rightarrow U[\bar{\Psi}(x)\gamma_{\mu}a^{\mu}\Psi(x)]U^{-1}$$

$$\neq \bar{\Psi}(\Lambda x)\gamma_{\mu}a^{\mu}\Psi(\Lambda x)$$

Lorentz violation is observable when a particle is moving in the fixed coordinate space

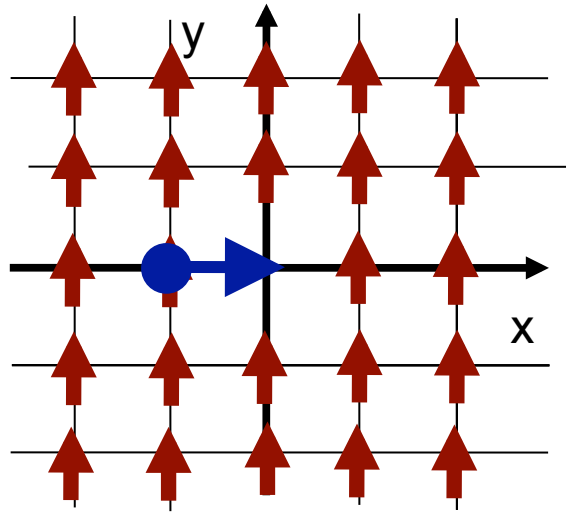

Under the **observer** Lorentz transformation:

$$\bar{\Psi}(x)\gamma_{\mu}a^{\mu}\Psi(x) \xrightarrow{\Lambda^{-1}} \bar{\Psi}(\Lambda^{-1}x)\gamma_{\mu}a^{\mu}\Psi(\Lambda^{-1}x)$$

Lorentz violation cannot be generated by observers motion (coordinate transformation is unbroken)

all observers agree for all observations

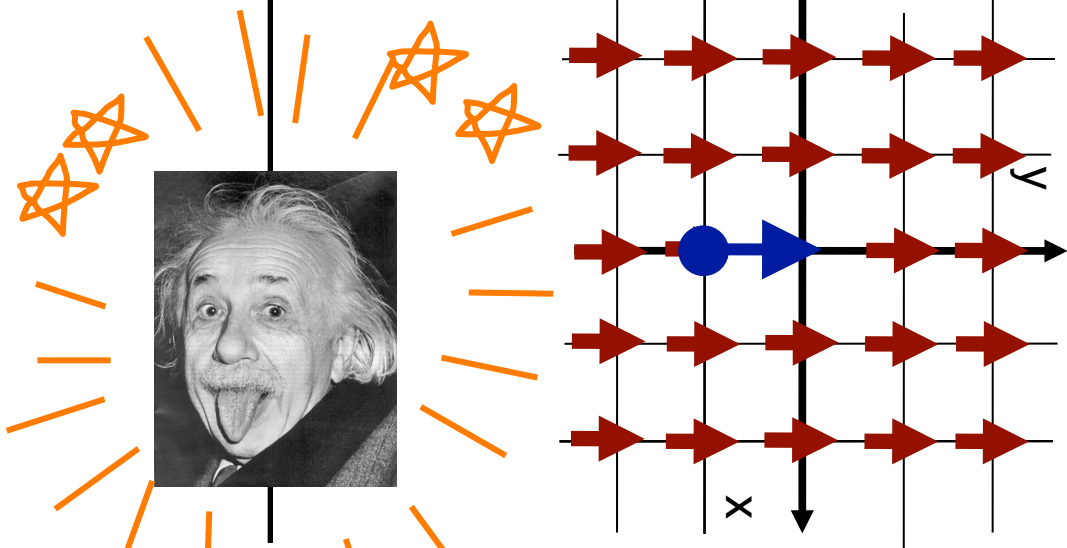

2. What is CPT violation?

CPT symmetry is the invariance under the CPT transformation

$$L \xrightarrow{\text{CPT}} \Theta L \Theta^{-1} = L' = L, \quad \Theta = \text{CPT}$$

C: charge conjugation

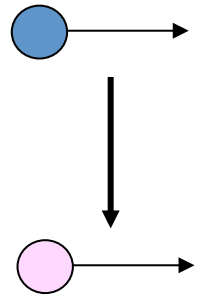

P: parity transformation

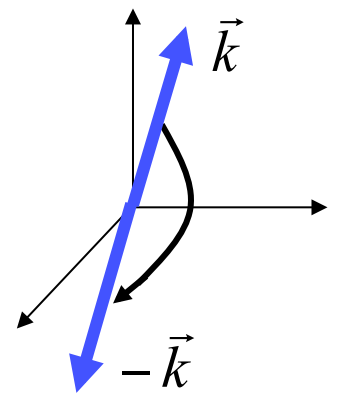

T: time reversal

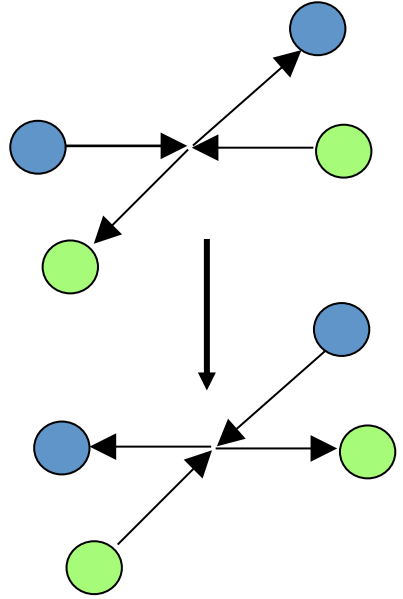

2. What is CPT violation?

$$\text{CPT phase} = (-1)^n$$

$n = \# \text{ Lorentz indices}$

CPT symmetry is the invariance under the CPT transformation

$$L \xrightarrow{\text{CPT}} \Theta L \Theta^{-1} = L' = L, \quad \Theta = \text{CPT}$$

CPT is the perfect symmetry of the Standard Model, due to **CPT theorem**

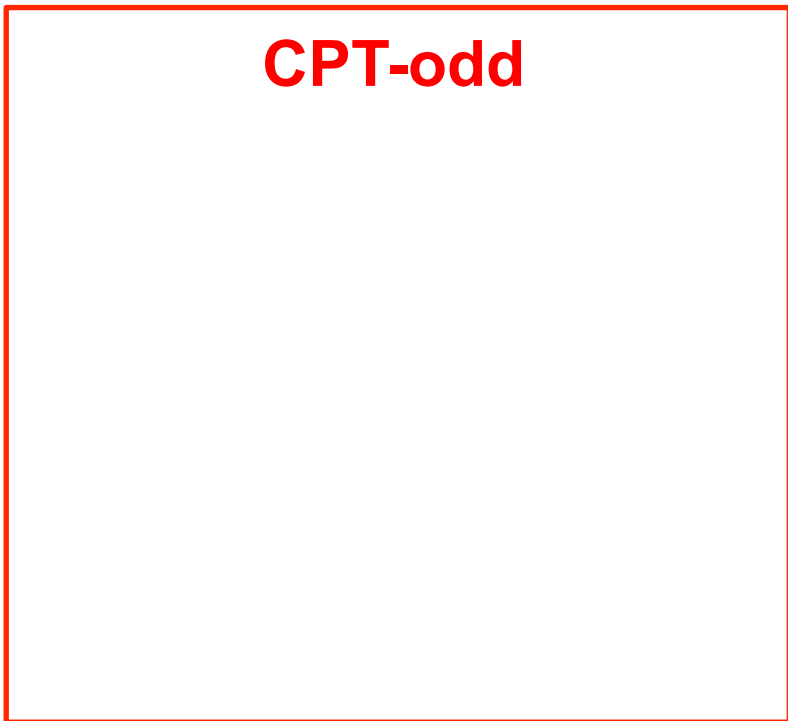
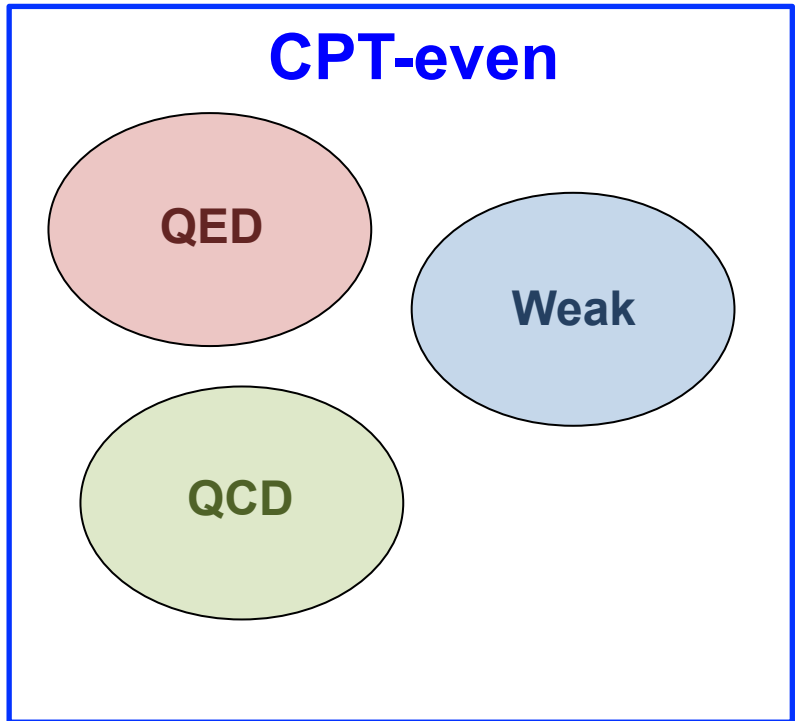

2. What is CPT violation?

CPT phase = $(-1)^n$
 $n = \# \text{ Lorentz indices}$

CPT symmetry is the invariance under the CPT transformation

$$L \xrightarrow{\text{CPT}} \Theta L \Theta^{-1} = L' = L, \quad \Theta = \text{CPT}$$

CPT is the perfect symmetry of the Standard Model, due to **CPT theorem**

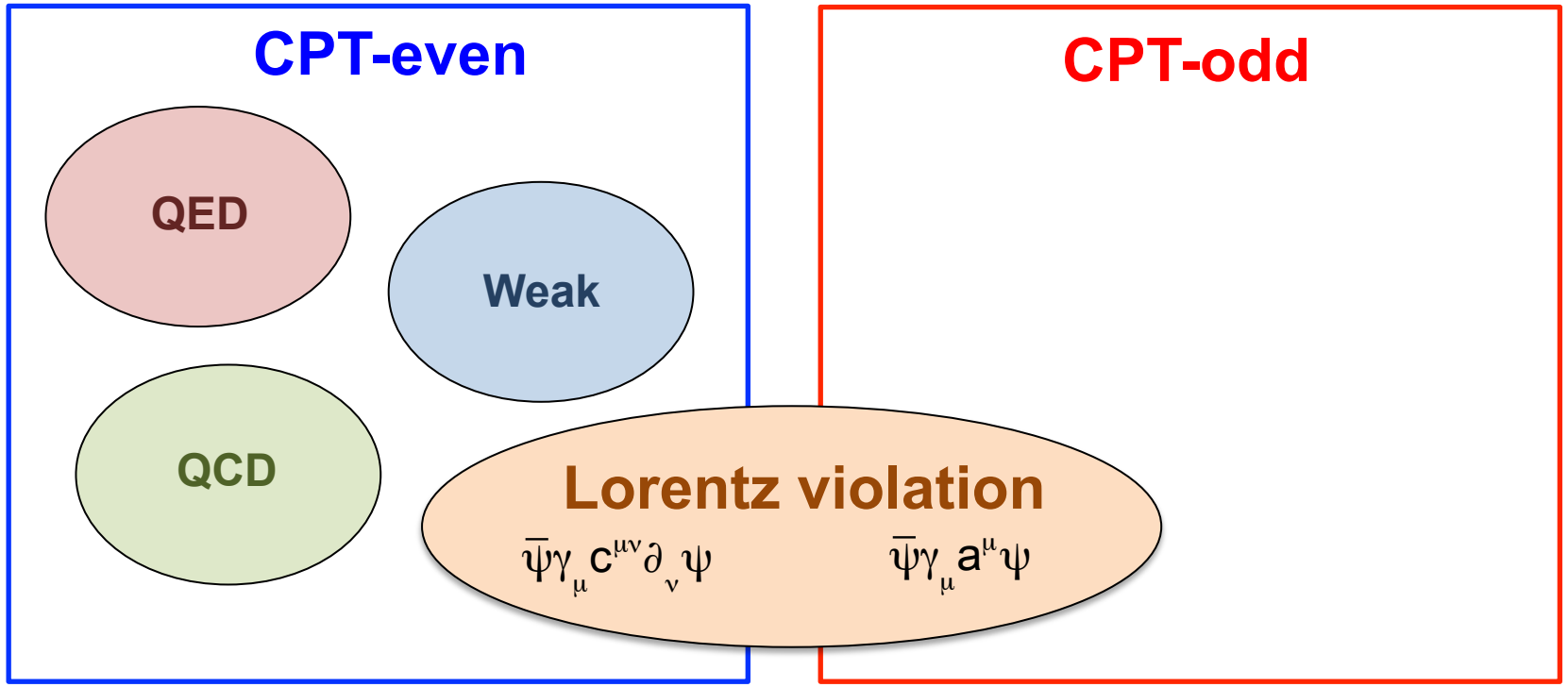

CPT-odd Lorentz violating coefficients (odd number Lorentz indices, e.g., a^{μ} , $g^{\lambda\mu\nu}$)
 CPT-even Lorentz violating coefficients (even number Lorentz indices, e.g., $c^{\mu\nu}$, $\kappa^{\alpha\beta\mu\nu}$)



2. CPT violation implies Lorentz violation

Lorentz invariance \longrightarrow CPT \longrightarrow Lorentz invariance of quantum field theory

CPT violation implies Lorentz violation in interactive quantum field theory.

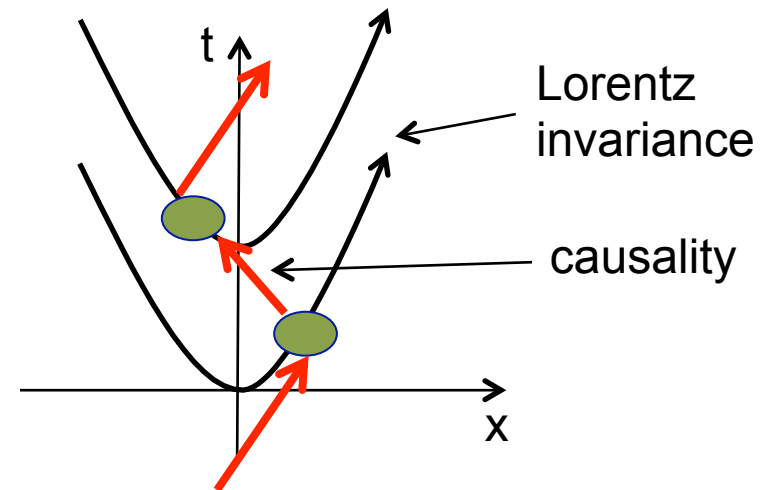
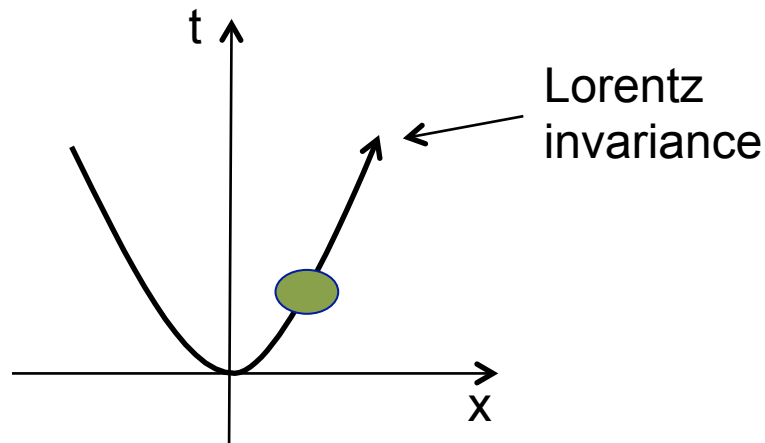

1. Spontaneous Lorentz symmetry breaking
2. What is Lorentz and CPT violation?
- 3. Modern test of Lorentz violation**
4. Lorentz violating neutrino oscillation
5. Test for Lorentz violation with MiniBooNE data
6. Test for Lorentz violation with Double Chooz data
7. Extra-terrestrial ultra-high energy neutrinos
8. Conclusion

3. Test of Lorentz violation

Lorentz violation is realized as a coupling of particle fields and background fields, so the basic strategy to find Lorentz violation is:

- (1) choose the coordinate system
- (2) write down the Lagrangian, including Lorentz-violating terms under the formalism
- (3) write down the observables using this Lagrangian

3. Test of Lorentz violation

Lorentz violation is realized as a coupling of particle fields and background fields, so the basic strategy to find Lorentz violation is:

- (1) choose the coordinate system
- (2) write down the Lagrangian, including Lorentz-violating terms under the formalism
- (3) write down the observables using this Lagrangian

- Neutrino beamline is described in Sun-centred coordinates

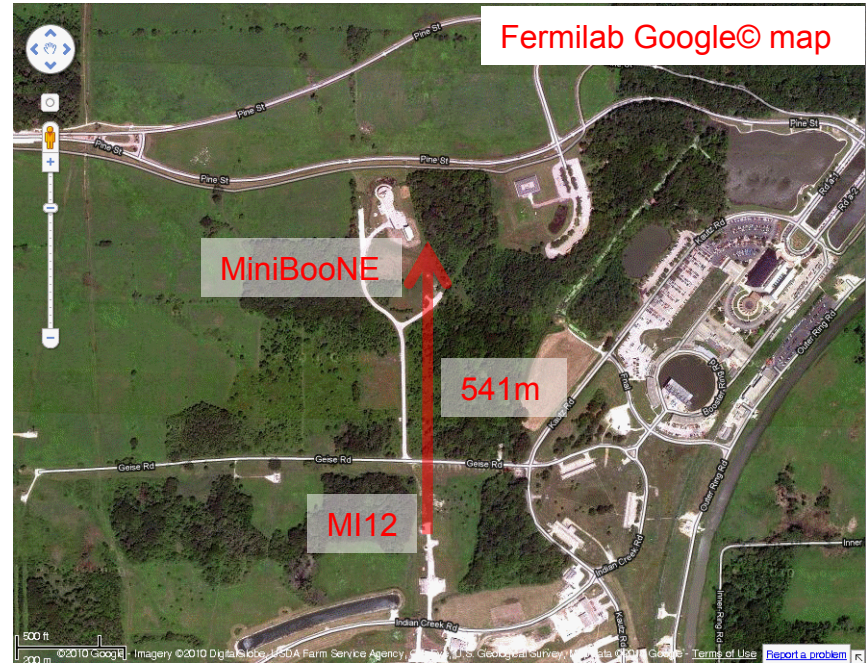
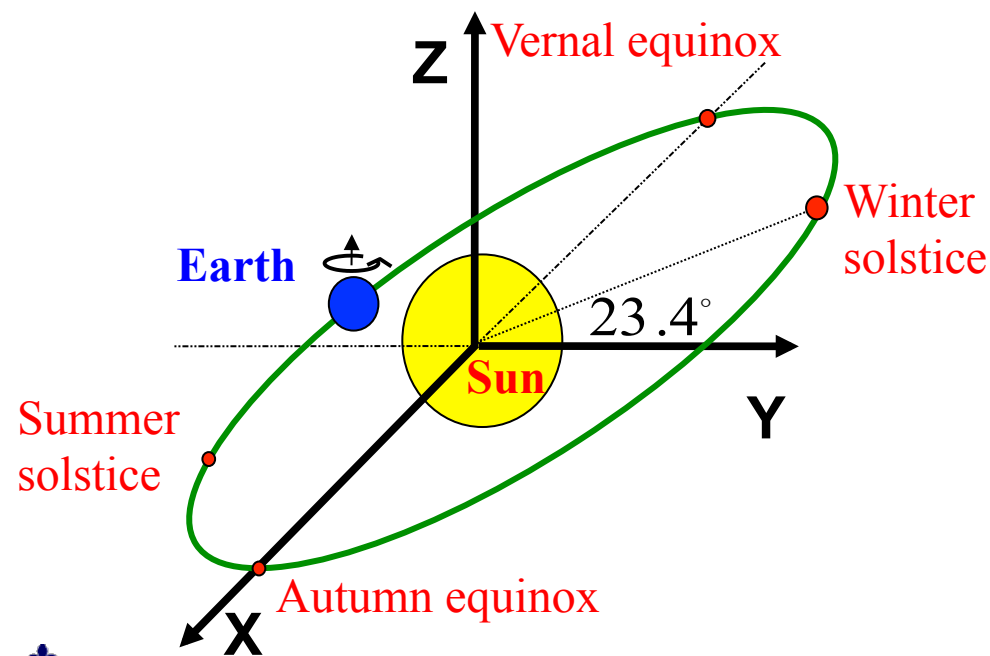

MiniBooNE beamline

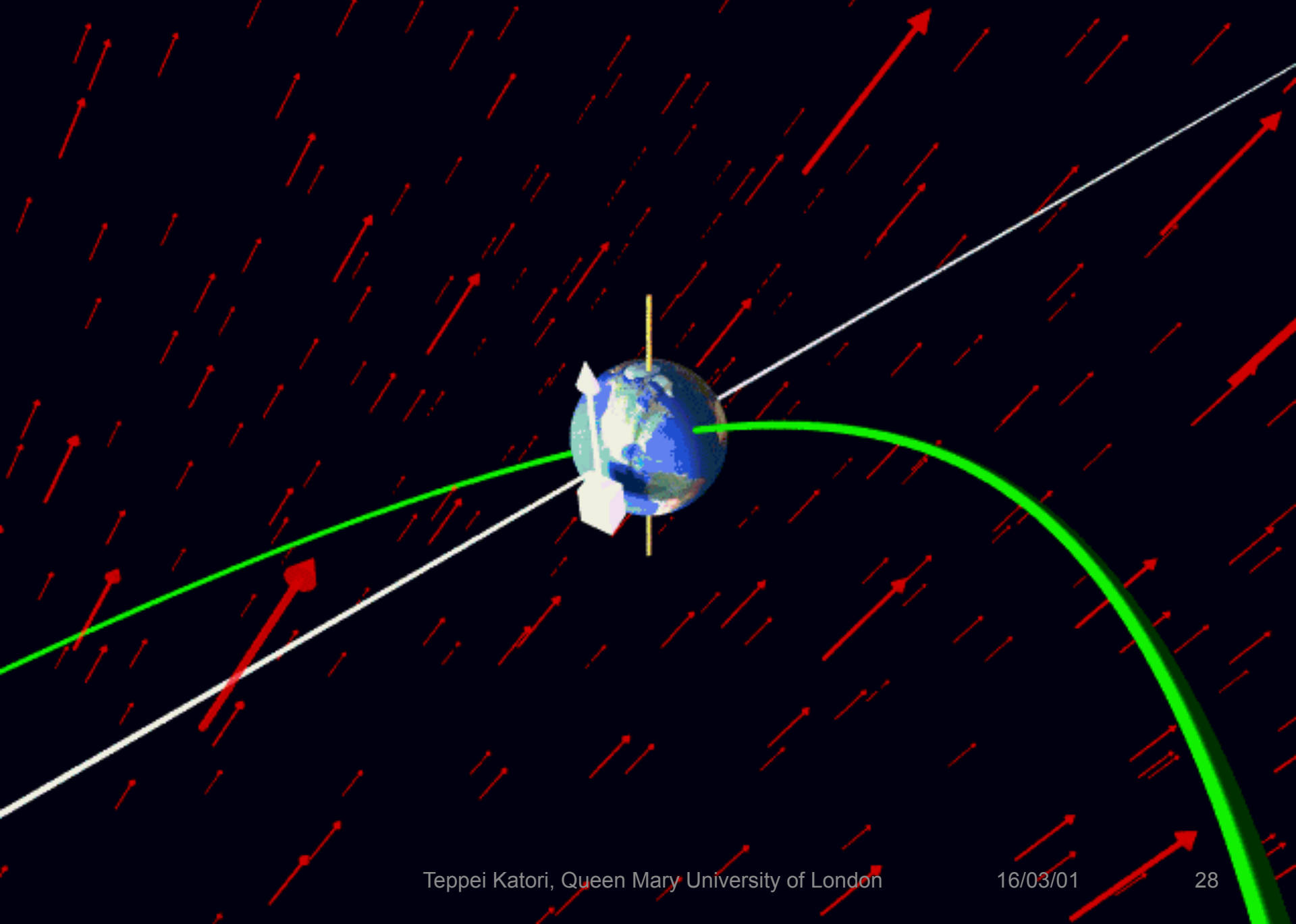

3. Test of Lorentz violation

Lorentz violation is realized as a coupling of particle fields and background fields, so the basic strategy to find Lorentz violation is:

- (1) choose the coordinate system
- (2) write down the Lagrangian, including Lorentz-violating terms under the formalism
- (3) write down the observables using this Lagrangian

Standard Model Extension (SME) is the standard formalism for the general search for Lorentz violation. SME is a minimum extension of QFT with Particle Lorentz violation

SME Lagrangian in neutrino sector

$$L = \frac{1}{2} i \bar{\psi}_A \Gamma_{AB}^{\nu} \partial_{\nu} \psi_B - M_{AB} \bar{\psi}_A \psi_B + h.c.$$

SME coefficients

$$\Gamma_{AB}^{\nu} = \gamma^{\nu} \delta_{AB} + c_{AB}^{\mu\nu} \gamma_{\mu} + d_{AB}^{\mu\nu} \gamma_{\mu} \gamma_5 + e_{AB}^{\nu} + i f_{AB}^{\nu} \gamma_5 + \frac{1}{2} g_{AB}^{\lambda\mu\nu} \sigma_{\lambda\mu} \dots$$

$$M_{AB} = m_{AB} + i m_{5AB} \gamma_5 + a_{AB}^{\mu} \gamma_{\mu} + b_{AB}^{\mu} \gamma_5 \gamma_{\mu} + \frac{1}{2} H_{AB}^{\mu\nu} \sigma_{\mu\nu} \dots$$

3. Test of Lorentz violation

Lorentz violation is realized as a coupling of particle fields and background fields, so the basic strategy to find Lorentz violation is:

- (1) choose the coordinate system
- (2) write down the Lagrangian, including Lorentz-violating terms under the formalism
- (3) write down the observables using this Lagrangian

Standard Model Extension (SME) is the standard formalism for the general search for Lorentz violation. SME is a minimum extension of QFT with Particle Lorentz violation

SME Lagrangian in neutrino sector

$$L = \frac{1}{2} i \bar{\psi}_A \Gamma_{AB}^\nu \partial_\nu \psi_B - M_{AB} \bar{\psi}_A \psi_B + h.c.$$

SME coefficients

$$\Gamma_{AB}^\nu = \gamma^\nu \delta_{AB} + c_{AB}^{\mu\nu} \gamma_\mu + d_{AB}^{\mu\nu} \gamma_\mu \gamma_5 + e_{AB}^\nu + i f_{AB}^\nu \gamma_5 + \frac{1}{2} g_{AB}^{\lambda\mu\nu} \sigma_{\lambda\mu} \dots$$

$$M_{AB} = m_{AB} + i m_{5AB} \gamma_5 + a_{AB}^\mu \gamma_\mu + b_{AB}^\mu \gamma_5 \gamma_\mu + \frac{1}{2} H_{AB}^{\mu\nu} \sigma_{\mu\nu} \dots$$

CPT odd

CPT even

3. Test of Lorentz violation

Lorentz violation is realized as a coupling of particle fields and background fields, so the basic strategy to find Lorentz violation is:

- (1) choose the coordinate system
- (2) write down the Lagrangian, including Lorentz-violating terms under the formalism
- (3) write down the observables using this Lagrangian

Various physics are predicted under SME, but among them, the smoking gun of Lorentz violation is the **sidereal time dependence** of the observables

solar time: 24h 00m 00.0s
sidereal time: 23h 56m 04.1s

$$\begin{array}{l} \text{sidereal frequency } \omega_{\oplus} = \frac{2\pi}{23h56m4.1s} \\ \text{sidereal time } T_{\oplus} \end{array}$$

Lorentz-violating neutrino oscillation probability for short-baseline experiments

$$P_{\nu_{\mu} \rightarrow \nu_e} = \left(\frac{L}{\hbar c} \right)^2 \left| (C)_{e\mu} + (A_s)_{e\mu} \sin \omega_{\oplus} T_{\oplus} + (A_c)_{e\mu} \cos \omega_{\oplus} T_{\oplus} + (B_s)_{e\mu} \sin 2\omega_{\oplus} T_{\oplus} + (B_c)_{e\mu} \cos 2\omega_{\oplus} T_{\oplus} \right|^2$$

3. Test of Lorentz violation

Lorentz violation is realized as a coupling of particle fields and background fields, so the basic strategy to find Lorentz violation is:

- (1) choose the coordinate system
- (2) write down the Lagrangian, including Lorentz-violating terms under the formalism
- (3) write down the observables using this Lagrangian

Various physics are predicted under SME, but among them, the smoking gun of Lorentz violation is the **sidereal time dependence** of the observables

solar time: 24h 00m 00.0s
sidereal time: 23h 56m 04.1s

$$\begin{array}{l} \text{sidereal frequency } \omega_{\oplus} = \frac{2\pi}{23h56m4.1s} \\ \text{sidereal time } T_{\oplus} \end{array}$$

Lorentz-violating neutrino oscillation probability for short-baseline experiments

$$P_{\nu_{\mu} \rightarrow \nu_e} = \left(\frac{L}{\hbar c} \right)^2 \left| \underbrace{(C)_{e\mu}}_{\text{time independent amplitude}} + \underbrace{(A_s)_{e\mu}}_{\text{sidereal time dependent amplitude}} \sin \omega_{\oplus} T_{\oplus} + \underbrace{(A_c)_{e\mu}}_{\text{sidereal time dependent amplitude}} \cos \omega_{\oplus} T_{\oplus} + \underbrace{(B_s)_{e\mu}}_{\text{sidereal time dependent amplitude}} \sin 2\omega_{\oplus} T_{\oplus} + \underbrace{(B_c)_{e\mu}}_{\text{sidereal time dependent amplitude}} \cos 2\omega_{\oplus} T_{\oplus} \right|^2$$

Sidereal variation analysis for short baseline neutrino oscillation is 5-parameter fitting problem

3. Modern tests of Lorentz violation

The latest meeting was in June 2013
(The next meeting is June 2016)

<http://www.physics.indiana.edu/~kostelec/faq.html>

CPT'13

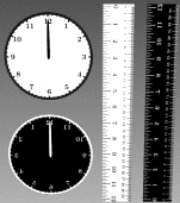

MEETING LINKS

[Meeting Home](#)
[Registration](#)
[Program](#)
[Proceedings](#)
[Travel](#)
[Accommodations](#)

LOCAL LINKS

[IUCSS](#)
[IU Physics](#)
[IU Astronomy](#)
[IU Bloomington](#)
[Bloomington area](#)

Sixth Meeting on **CPT AND LORENTZ SYMMETRY**

June 17-21, 2013

Indiana University, Bloomington

The *Sixth Meeting on CPT and Lorentz Symmetry* will be held in the [Physics Department, Indiana University](#) in [Bloomington](#), Indiana, U.S.A. on June 17-21, 2013. The meeting will focus on tests of these fundamental symmetries and on related theoretical issues, including scenarios for possible violations.

Topics include:

- experimental and observational searches for CPT and Lorentz violation involving
 - accelerator and collider experiments
 - atomic, nuclear, and particle decays
 - birefringence, dispersion, and anisotropy in cosmological sources
 - clock-comparison measurements
 - CMB polarization
 - electromagnetic resonant cavities and lasers
 - tests of the equivalence principle
 - gauge and Higgs particles
 - high-energy astrophysical observations
 - laboratory and gravimetric tests of gravity
 - matter interferometry
 - neutrino oscillations and propagation, neutrino-antineutrino mixing

Atomic Interferometer
 $(a,c)^{n,p,e} < 10^{-6}$



PRL106(2011)151102

CERN Antiproton Decelerator
 $(M_p - \bar{M}_p)/M_p < 10^{-8}$

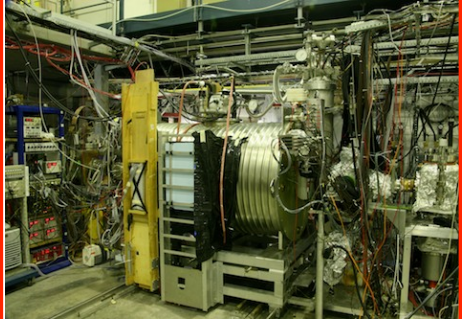

Nature419(2002)456

Spin torsion pendulum
 $b_e < 10^{-30}$ GeV



Neutrino TOF
 $(v-c)/c < 10^{-5}$



PRD76(2007)072005
 JHEP11(2012)049

Tevatron and LEP
 $-5.8 \times 10^{-12} < \kappa_{tr} - 4/3 c_e^{00} < 1.2 \times 10^{-11}$



PRL102(2009)170402

GRB vacuum birefringence
 $\kappa_{e+}, \kappa_{o-} < 10^{-37}$

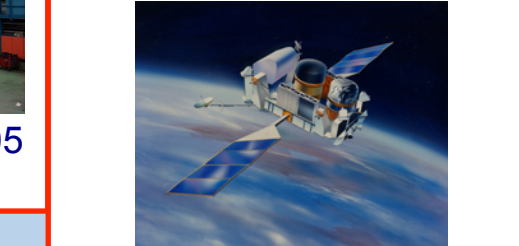

PRL97(2006)140401

KTev/KLOE (strange)
 $\Delta a_K < 10^{-22}$ GeV
 FOCUS (charm)
 $\Delta a_D < 10^{-16}$ GeV
 BaBar/Belle (bottom)
 $\Delta m_B/m_B < 10^{-14}$

Limits from all these experiments >60 page tables!
 Rev.Mod.Phys.83(2011)11
 ArXiv:0801.0287v9

- laboratory and gravimetric tests of gravity
- matter interferometry
- neutrino oscillations and propagation, neutrino-antineutrino mixing
- oscillations and decays of K, B, D mesons

Test of Lorentz invariance with neutrino oscillation is very interesting, because neutrinos are the least known standard model particles!

uble gas maser
 (station) < 10^{-33} GeV
 (boost) < 10^{-27} GeV

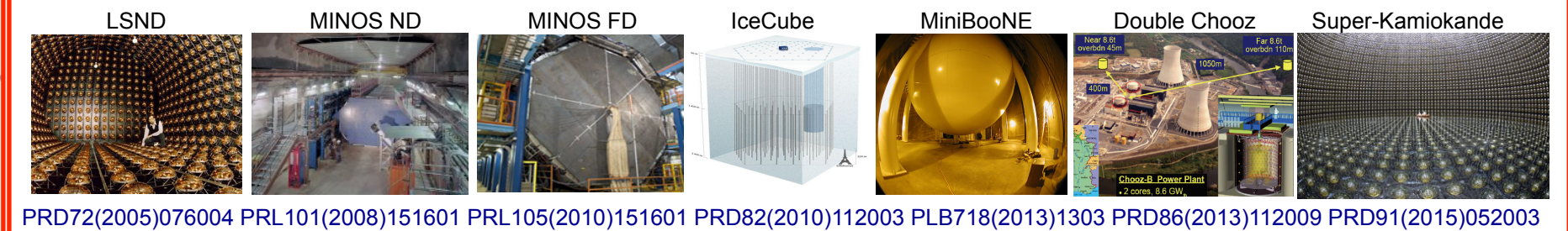

PRD72(2005)076004 PRL101(2008)151601 PRL105(2010)151601 PRD82(2010)112003 PLB718(2013)1303 PRD86(2013)112009 PRD91(2015)052003
 PLB556(2003)7
 PRL100(2008)131802
 PRL105(2010)151604
 PRL107(2010)171604
 PRL99(2007)050401

classical and quantum field the
 mathematical foundations, Fin

uar

1. Spontaneous Lorentz symmetry breaking
2. What is Lorentz and CPT violation?
3. Modern test of Lorentz violation
- 4. Lorentz violating neutrino oscillation**
5. Test for Lorentz violation with MiniBooNE data
6. Test for Lorentz violation with Double Chooz data
7. Extra-terrestrial ultra-high energy neutrinos
8. Conclusion

4. Neutrinos

Neutrinos in the standard model

The standard model describes 6 quarks and 6 leptons and 3 types of force carriers.

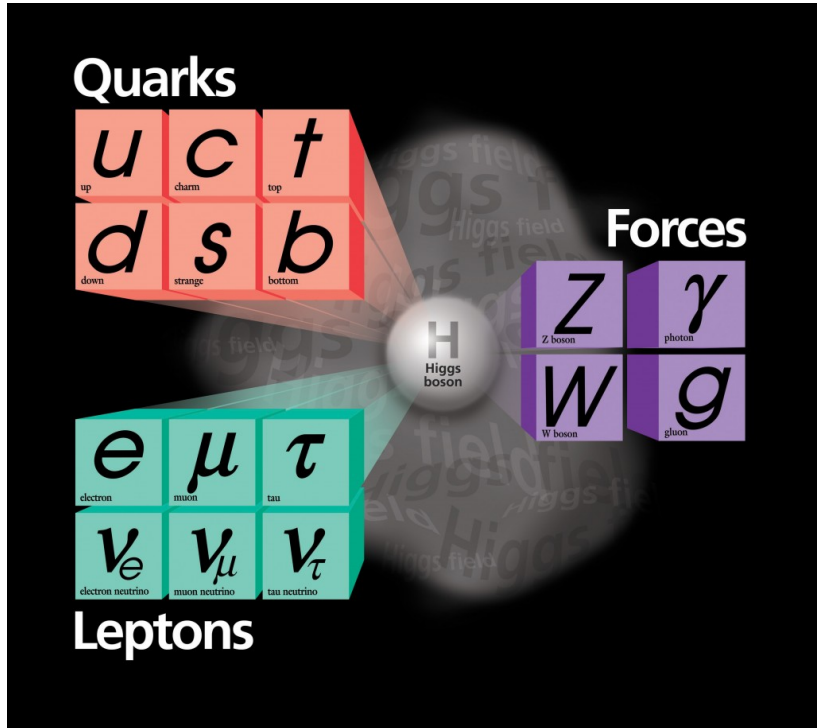

Neutrinos are special because,

1. they only interact with weak nuclear force.

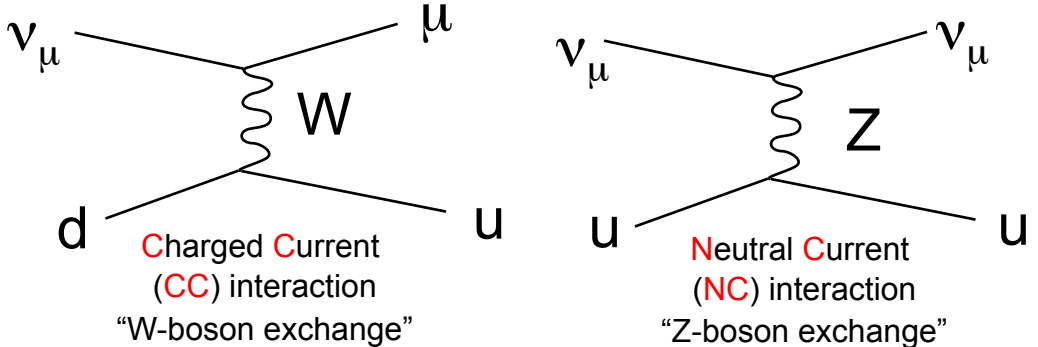

2. interaction eigenstate is not Hamiltonian eigenstate (propagation eigenstate). Thus propagation of neutrinos changes their species, called **neutrino oscillation**.

4. Neutrino oscillations, natural interferometers

Neutrino oscillation is an interference experiment (cf. double slit experiment)

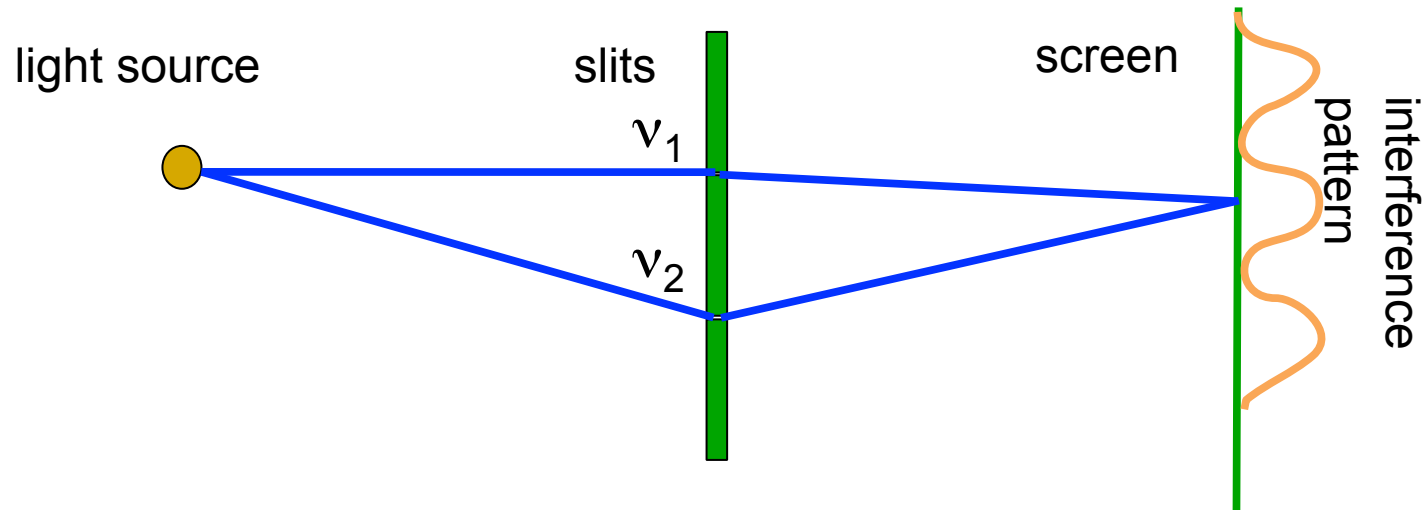

For double slit experiment, if path ν_1 and path ν_2 have different length, they have different phase rotations and it causes interference.

4. Neutrino oscillations, natural interferometers

Neutrino oscillation is an interference experiment (cf. double slit experiment)

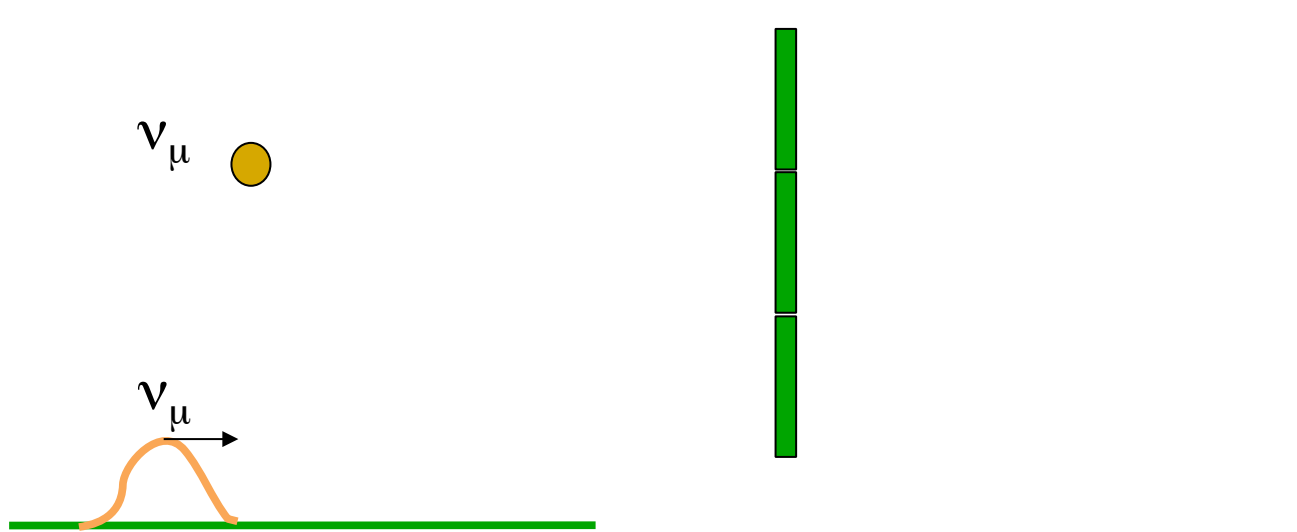

If 2 neutrino Hamiltonian eigenstates, ν_1 and ν_2 , have different phase rotation, they cause quantum interference.

4. Neutrino oscillations, natural interferometers

Neutrino oscillation is an interference experiment (cf. double slit experiment)

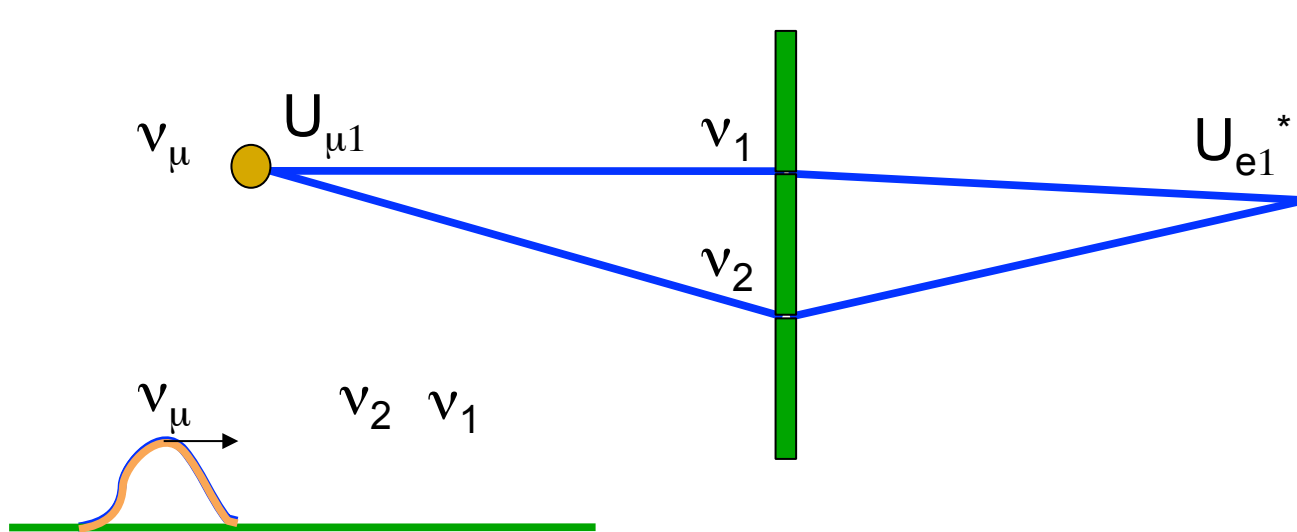

If 2 neutrino Hamiltonian eigenstates, ν_1 and ν_2 , have different phase rotation, they cause quantum interference.

If ν_1 and ν_2 , have different mass, they have different velocity, so thus different phase rotation.

4. Neutrino oscillations, natural interferometers

Neutrino oscillation is an interference experiment (cf. double slit experiment)

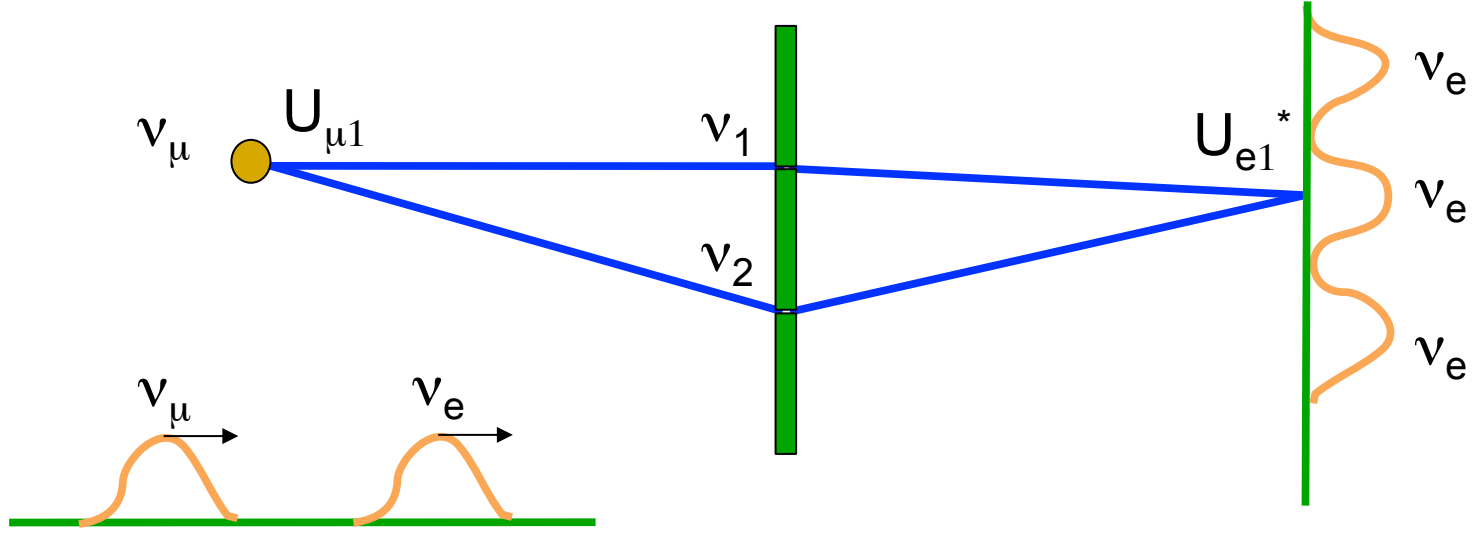

If 2 neutrino Hamiltonian eigenstates, ν_1 and ν_2 , have different phase rotation, they cause quantum interference.

If ν_1 and ν_2 , have different mass, they have different velocity, so thus different phase rotation.

The detection may be different flavor (neutrino oscillations).

4. Lorentz violation with neutrino oscillation

Neutrino oscillation is an interference experiment (cf. double slit experiment)

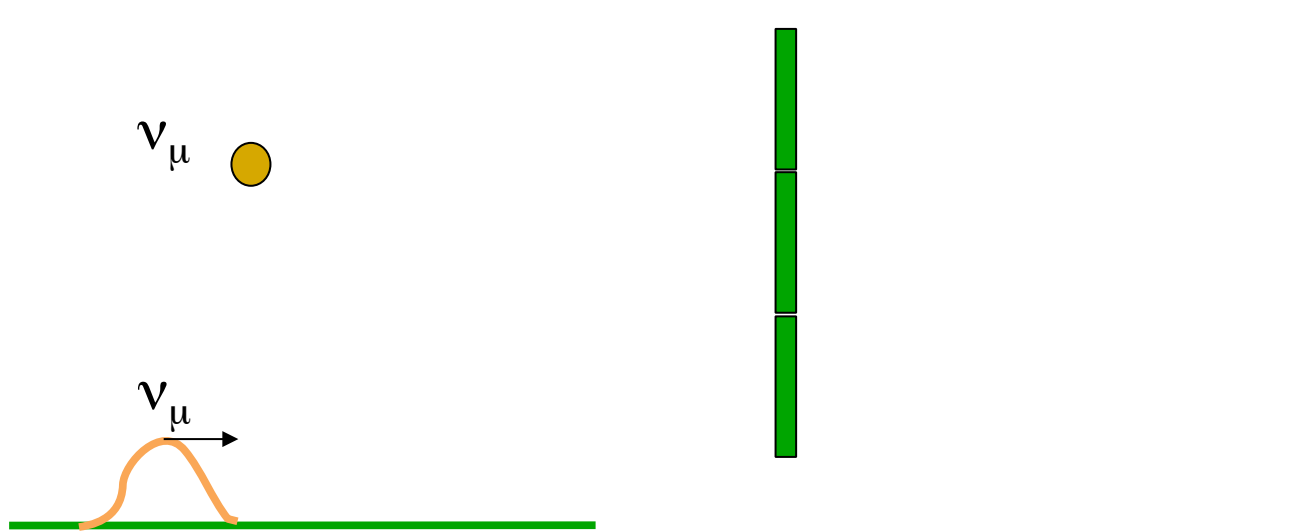

If 2 neutrino Hamiltonian eigenstates, ν_1 and ν_2 , have different phase rotation, they cause quantum interference.

4. Lorentz violation with neutrino oscillation

Neutrino oscillation is an interference experiment (cf. double slit experiment)

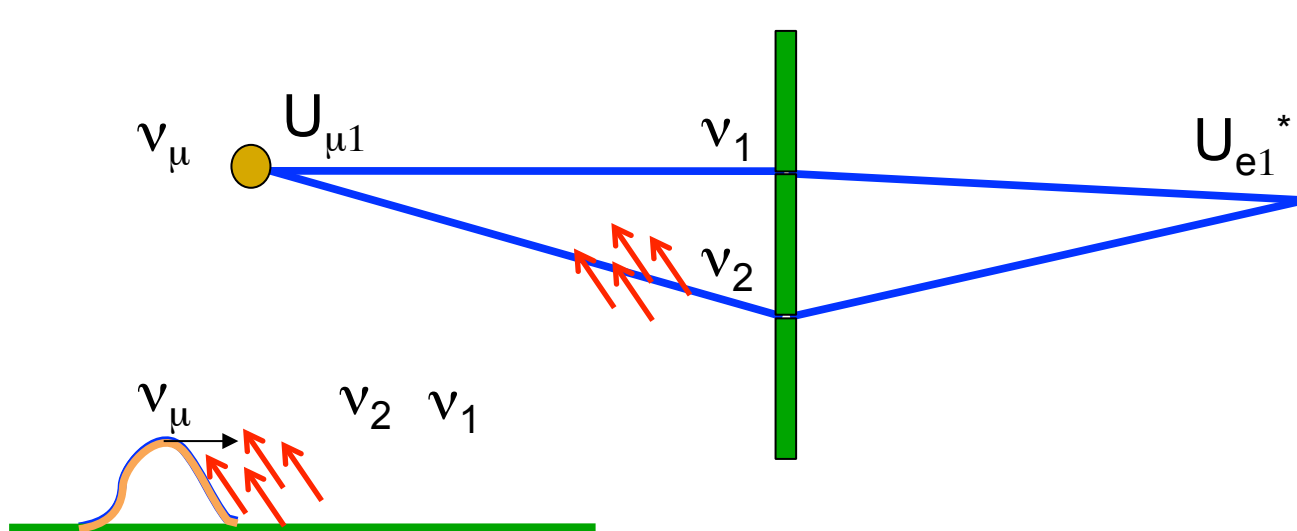

If 2 neutrino Hamiltonian eigenstates, ν_1 and ν_2 , have different phase rotation, they cause quantum interference.

If ν_1 and ν_2 , have different coupling with Lorentz violating field, neutrinos also oscillate. The sensitivity of neutrino oscillation is comparable the target scale of Lorentz violation ($<10^{-19}\text{GeV}$).

4. Lorentz violation with neutrino oscillation

Neutrino oscillation is an interference experiment (cf. double slit experiment)

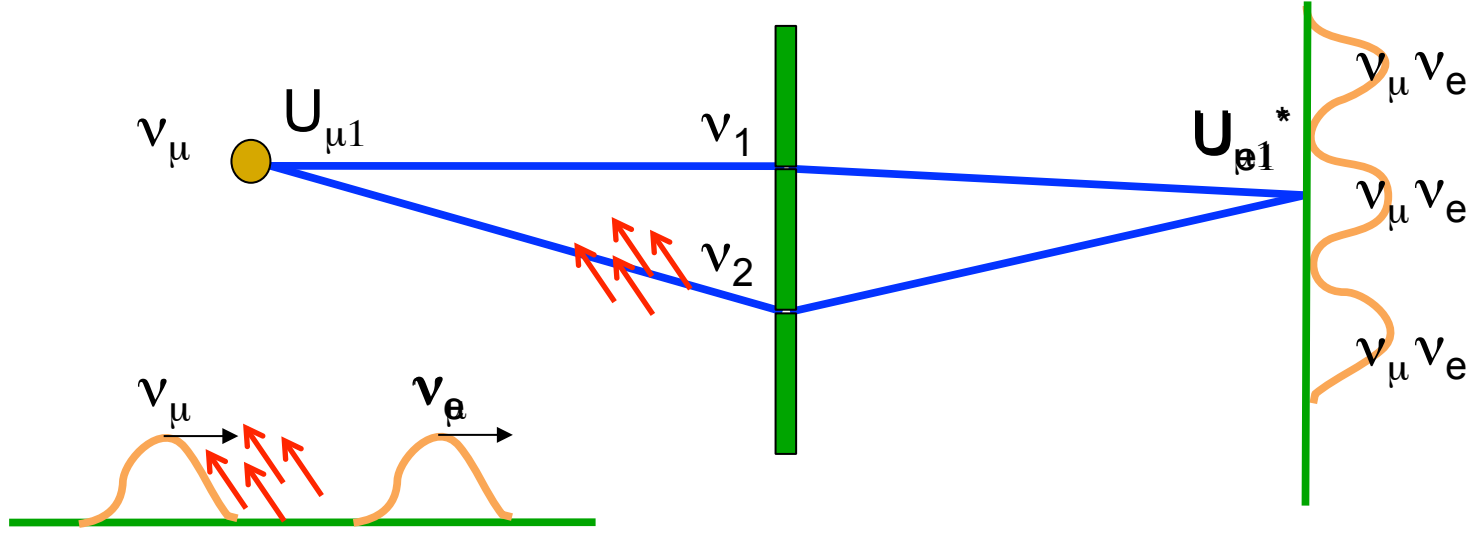

If 2 neutrino Hamiltonian eigenstates, ν_1 and ν_2 , have different phase rotation, they cause quantum interference.

If ν_1 and ν_2 , have different coupling with Lorentz violating field, neutrinos also oscillate. The sensitivity of neutrino oscillation is comparable the target scale of Lorentz violation ($<10^{-19}\text{GeV}$).

If neutrino oscillation is caused by Lorentz violation, interference pattern (oscillation probability) may have sidereal time dependence.

1. Spontaneous Lorentz symmetry breaking
2. What is Lorentz and CPT violation?
3. Modern test of Lorentz violation
4. Lorentz violating neutrino oscillation
- 5. Test for Lorentz violation with MiniBooNE data**
6. Test for Lorentz violation with Double Chooz data
7. Extra-terrestrial ultra-high energy neutrinos
8. Conclusion

5. MiniBooNE experiment

MiniBooNE is a short-baseline neutrino oscillation experiment at Fermilab.

$$\nu_{\mu} \xrightarrow{\text{oscillation}} \nu_e + n \rightarrow e^{-} + p$$

$$\bar{\nu}_{\mu} \xrightarrow{\text{oscillation}} \bar{\nu}_e + p \rightarrow e^{+} + n$$

Booster Neutrino Beamline (BNB) creates $\sim 800(600)$ MeV neutrino(anti-neutrino) by pion decay-in-flight. Cherenkov radiation from the charged leptons are observed by MiniBooNE Cherenkov detector to reconstruct neutrino energy.

FNAL Booster



Magnetic focusing horn

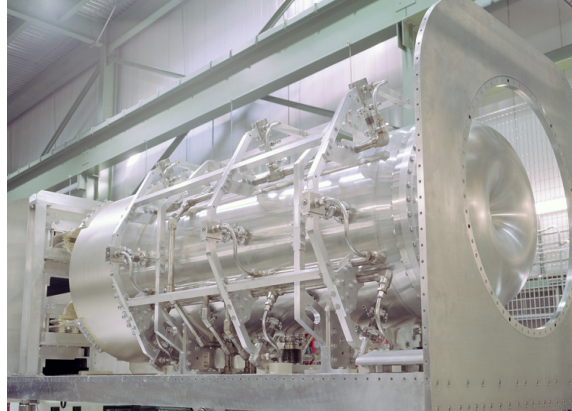

$\sim 520\text{m}$
→

MiniBooNE detector

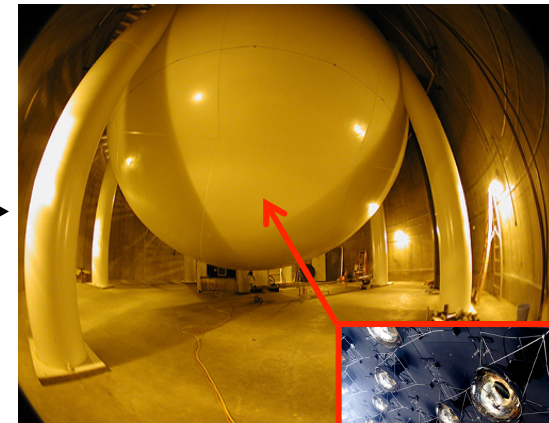

primary beam
→
(8 GeV protons)

secondary beam
→
(1-2 GeV pions)

tertiary beam
→
(800 MeV ν_{μ} , 600 MeV anti- ν_{μ})



1280 of 8" PMT

5. MiniBooNE experiment

MiniBooNE is a short-baseline neutrino oscillation experiment at Fermilab.

$$\nu_{\mu} \xrightarrow{\text{oscillation}} \nu_e + n \rightarrow e^{-} + p$$

$$\bar{\nu}_{\mu} \xrightarrow{\text{oscillation}} \bar{\nu}_e + p \rightarrow e^{+} + n$$

MiniBooNE observed unexplained excess of events

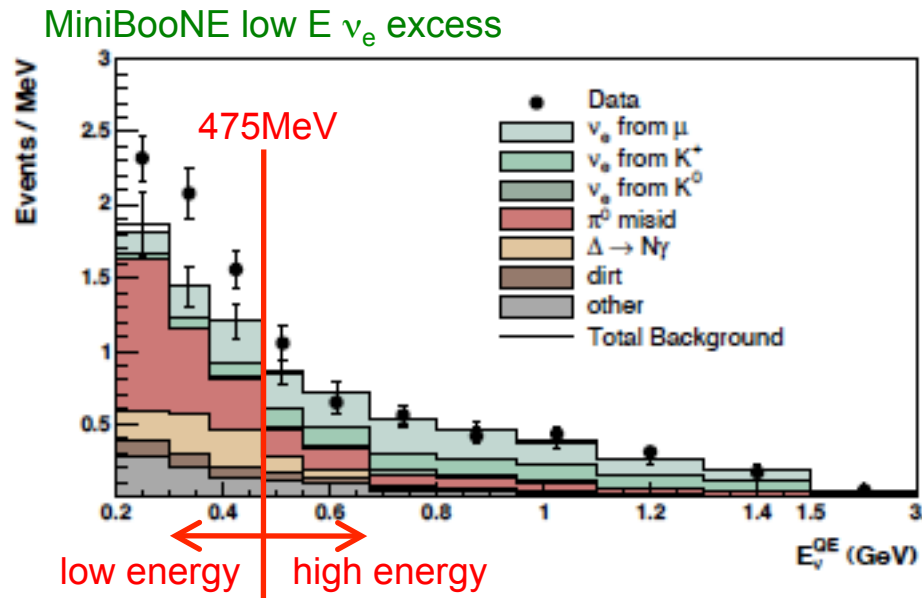

These excesses are not predicted by neutrino Standard Model (ν SM), therefore it might sterile neutrino or other new physics, such as Lorentz violation
→ Oscillation candidate events may have sidereal time dependence!

5. Lorentz violation with MiniBooNE neutrino data

MiniBooNE is a short-baseline neutrino oscillation experiment at Fermilab.

$$\nu_{\mu} \xrightarrow{\text{oscillation}} \nu_e + n \rightarrow e^{-} + p$$

$$\bar{\nu}_{\mu} \xrightarrow{\text{oscillation}} \bar{\nu}_e + p \rightarrow e^{+} + n$$

Electron neutrino candidate data prefer **sidereal time independent solution (flat)**

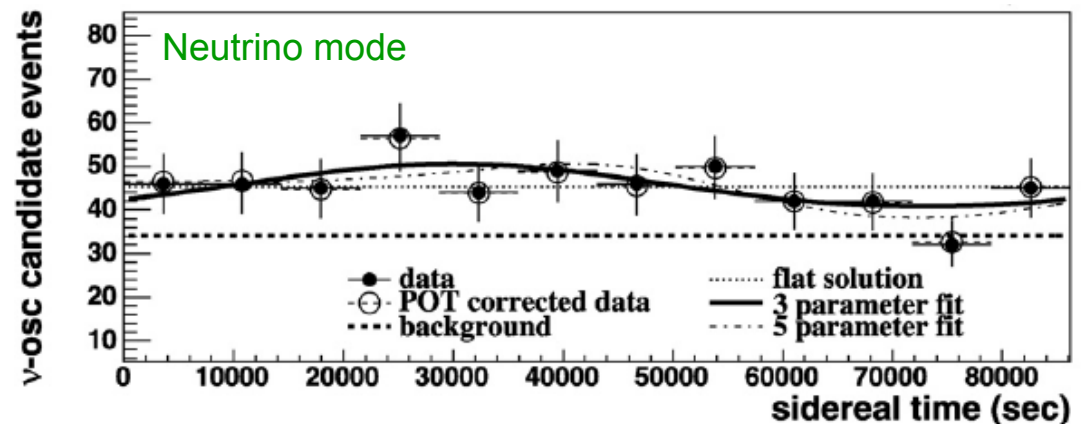

5. Lorentz violation with MiniBooNE neutrino data

MiniBooNE is a short-baseline neutrino oscillation experiment at Fermilab.

$$\nu_{\mu} \xrightarrow{\text{oscillation}} \nu_e + n \rightarrow e^{-} + p$$

$$\bar{\nu}_{\mu} \xrightarrow{\text{oscillation}} \bar{\nu}_e + p \rightarrow e^{+} + n$$

Electron neutrino candidate data prefer **sidereal time independent solution (flat)**

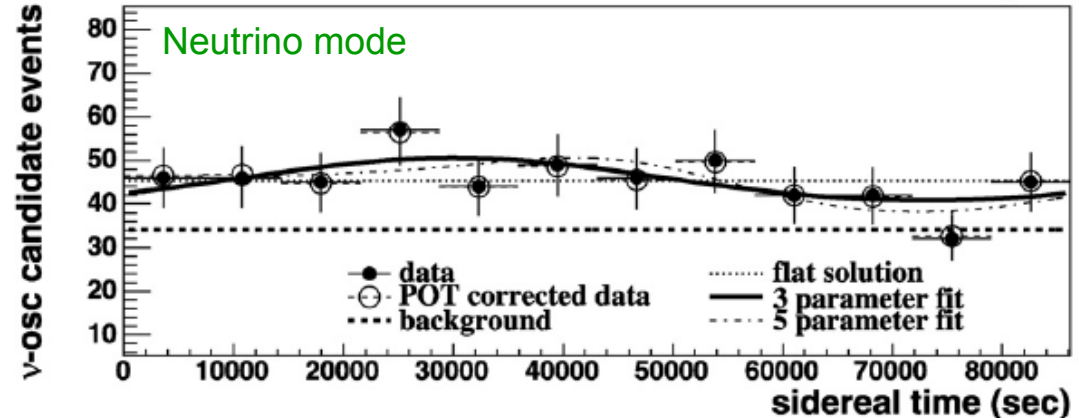

Electron antineutrino candidate data prefer **sidereal time dependent solution**, however statistical significance is marginal

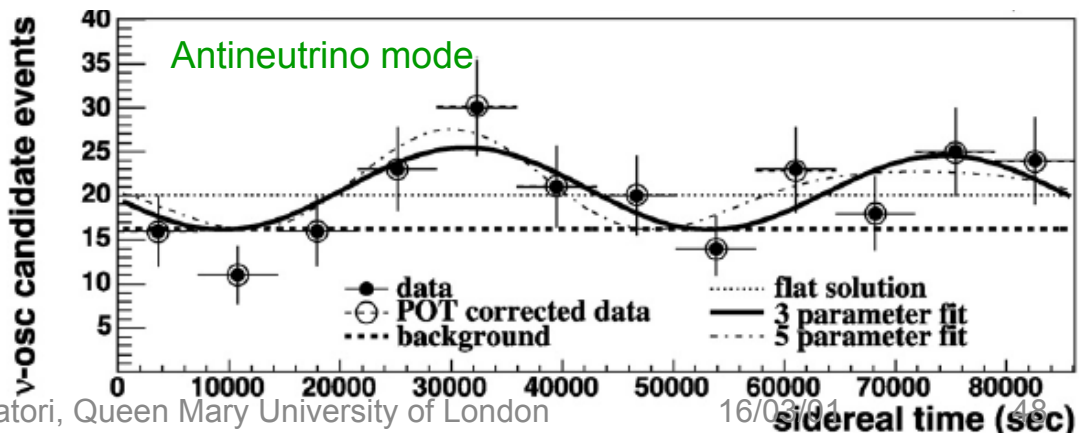

We find no evidence of Lorentz violation

5. Lorentz violation with MiniBooNE neutrino data

MiniBooNE is a short-baseline neutrino oscillation experiment at Fermilab.

$$\nu_{\mu} \xrightarrow{\text{oscillation}} \nu_e + n \rightarrow e^{-} + p$$

$$\bar{\nu}_{\mu} \xrightarrow{\text{oscillation}} \bar{\nu}_e + p \rightarrow e^{+} + n$$

Since we find no evidence of Lorentz violation, we set limits on the combination SME coefficients.

	ν -mode BF	2σ limit	$\bar{\nu}$ -mode BF	2σ limit
$ (\mathcal{C})_{e\mu} $	$3.1 \pm 0.6 \pm 0.9$	< 4.2	$0.1 \pm 0.8 \pm 0.1$	< 2.6
$ (\mathcal{A}_S)_{e\mu} $	$0.6 \pm 0.9 \pm 0.3$	< 3.3	$2.4 \pm 1.3 \pm 0.5$	< 3.9
$ (\mathcal{A}_C)_{e\mu} $	$0.4 \pm 0.9 \pm 0.4$	< 4.0	$2.1 \pm 1.2 \pm 0.4$	< 3.7

SME coefficients combination (unit 10^{-20} GeV)

$ (\mathcal{C})_{e\mu} $	$\pm[(a_L)_{e\mu}^T + 0.75(a_L)_{e\mu}^Z] - \langle E \rangle [1.22(c_L)_{e\mu}^{TT} + 1.50(c_L)_{e\mu}^{TZ} + 0.34(c_L)_{e\mu}^{ZZ}]$
$ (\mathcal{A}_S)_{e\mu} $	$\pm[0.66(a_L)_{e\mu}^Y] - \langle E \rangle [1.33(c_L)_{e\mu}^{TY} + 0.99(c_L)_{e\mu}^{YZ}]$
$ (\mathcal{A}_C)_{e\mu} $	$\pm[0.66(a_L)_{e\mu}^X] - \langle E \rangle [1.33(c_L)_{e\mu}^{TX} + 0.99(c_L)_{e\mu}^{XZ}]$

5. Summary of results

LSND experiment

LSND is a short-baseline neutrino oscillation experiment at Los Alamos.

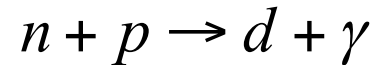
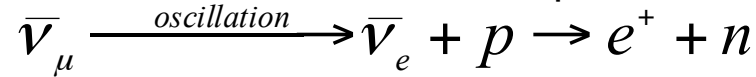

LSND saw the 3.8σ excess of electron antineutrinos from muon antineutrino beam; since this excess is not understood by neutrino Standard Model, it might be new physics

Data is consistent with flat solution, but sidereal time solution is not excluded.

LSND oscillation candidate sidereal time distribution

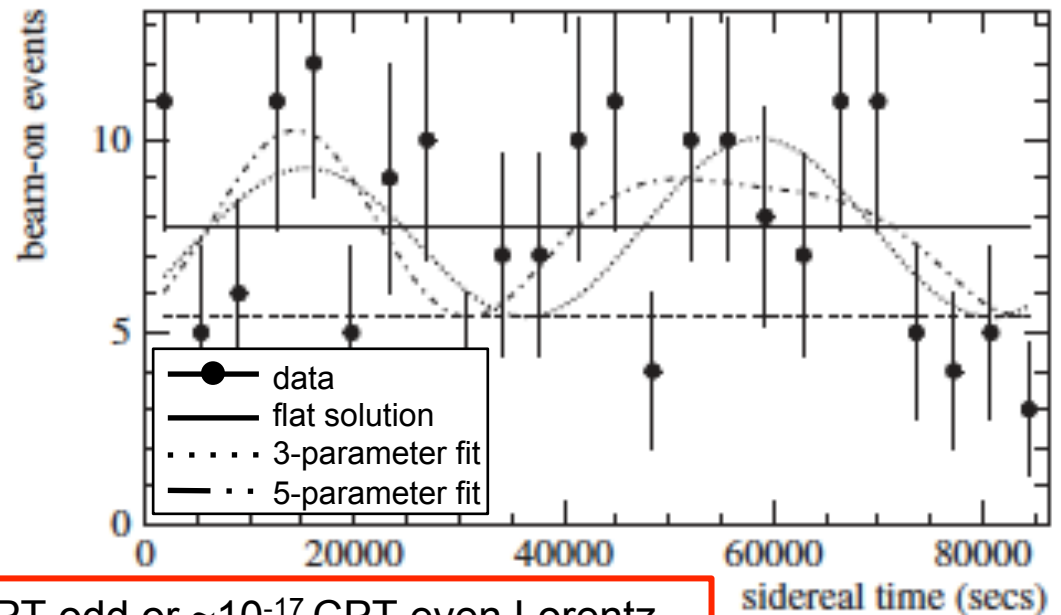
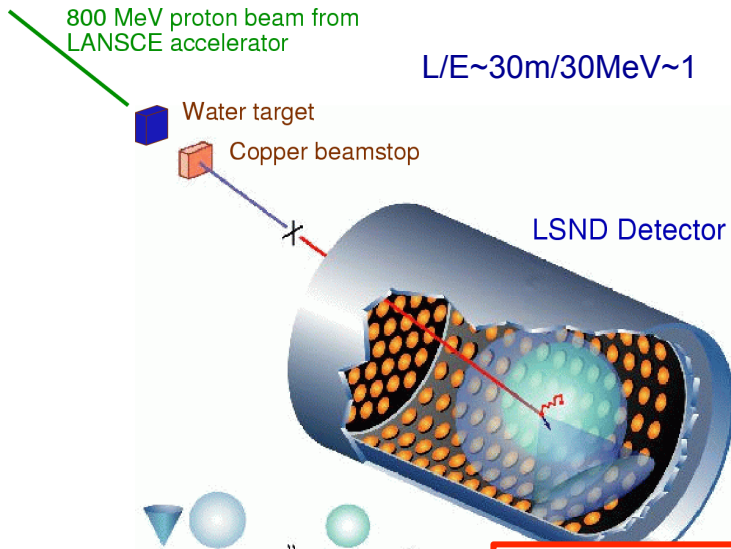

$\sim 10^{-19}$ GeV CPT-odd or $\sim 10^{-17}$ GeV CPT-even Lorentz violation could be the solution of LSND excess

5. Summary of results

Since we find no evidence of Lorentz violation from MiniBooNE analysis, we set limits on the SME coefficients.

These limits exclude SME values to explain LSND data, **therefore there is no simple Lorentz violation motivated scenario to accommodate LSND and MiniBooNE results simultaneously**

Coefficient	$e\mu$ (ν mode low energy region)	$e\mu$ ($\bar{\nu}$ mode combined region)
$\text{Re}(a_L)^T$ or $\text{Im}(a_L)^T$	4.2×10^{-20} GeV	2.6×10^{-20} GeV
$\text{Re}(a_L)^X$ or $\text{Im}(a_L)^X$	6.0×10^{-20} GeV	5.6×10^{-20} GeV
$\text{Re}(a_L)^Y$ or $\text{Im}(a_L)^Y$	5.0×10^{-20} GeV	5.9×10^{-20} GeV
$\text{Re}(a_L)^Z$ or $\text{Im}(a_L)^Z$	5.6×10^{-20} GeV	3.5×10^{-20} GeV
$\text{Re}(c_L)^{XY}$ or $\text{Im}(c_L)^{XY}$	—	—
$\text{Re}(c_L)^{XZ}$ or $\text{Im}(c_L)^{XZ}$	1.1×10^{-19}	6.2×10^{-20}
$\text{Re}(c_L)^{YZ}$ or $\text{Im}(c_L)^{YZ}$	9.2×10^{-20}	6.5×10^{-20}
$\text{Re}(c_L)^{XX}$ or $\text{Im}(c_L)^{XX}$	—	—
$\text{Re}(c_L)^{YY}$ or $\text{Im}(c_L)^{YY}$	—	—
$\text{Re}(c_L)^{ZZ}$ or $\text{Im}(c_L)^{ZZ}$	3.4×10^{-19}	1.3×10^{-19}
$\text{Re}(c_L)^{TT}$ or $\text{Im}(c_L)^{TT}$	9.6×10^{-20}	3.6×10^{-20}
$\text{Re}(c_L)^{TX}$ or $\text{Im}(c_L)^{TX}$	8.4×10^{-20}	4.6×10^{-20}
$\text{Re}(c_L)^{TY}$ or $\text{Im}(c_L)^{TY}$	6.9×10^{-20}	4.9×10^{-20}
$\text{Re}(c_L)^{TZ}$ or $\text{Im}(c_L)^{TZ}$	7.8×10^{-20}	2.9×10^{-20}



1. Spontaneous Lorentz symmetry breaking
2. What is Lorentz and CPT violation?
3. Modern test of Lorentz violation
4. Lorentz violating neutrino oscillation
5. Test for Lorentz violation with MiniBooNE data
6. Test for Lorentz violation with Double Chooz data
7. Extra-terrestrial ultra-high energy neutrinos
8. Conclusion

6. Double Chooz experiment

Reactor electron antineutrino disappearance

- Double Chooz, DayaBay and RENO experiments observed disappearance signals

BREAKTHROUGH PRIZE



Yifang Wang and the
Daya Bay Collaboration



DayaBay collaboration won
Breakthrough prize 2016

Kam-Biu Luk and the
Daya Bay Collaboration

Double Chooz reactor neutrino candidate

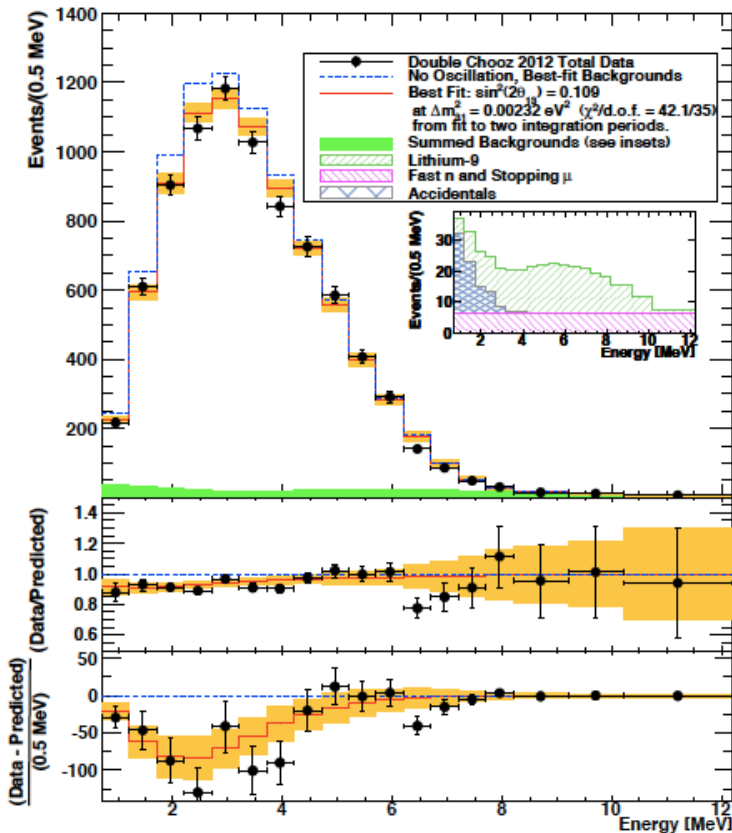

6. Double Chooz experiment

Reactor electron antineutrino disappearance

- Double Chooz, DayaBay and RENO experiments observed disappearance

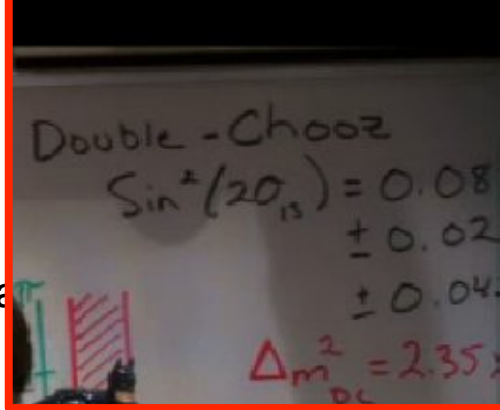

Double Chooz reactor neutrino candidate

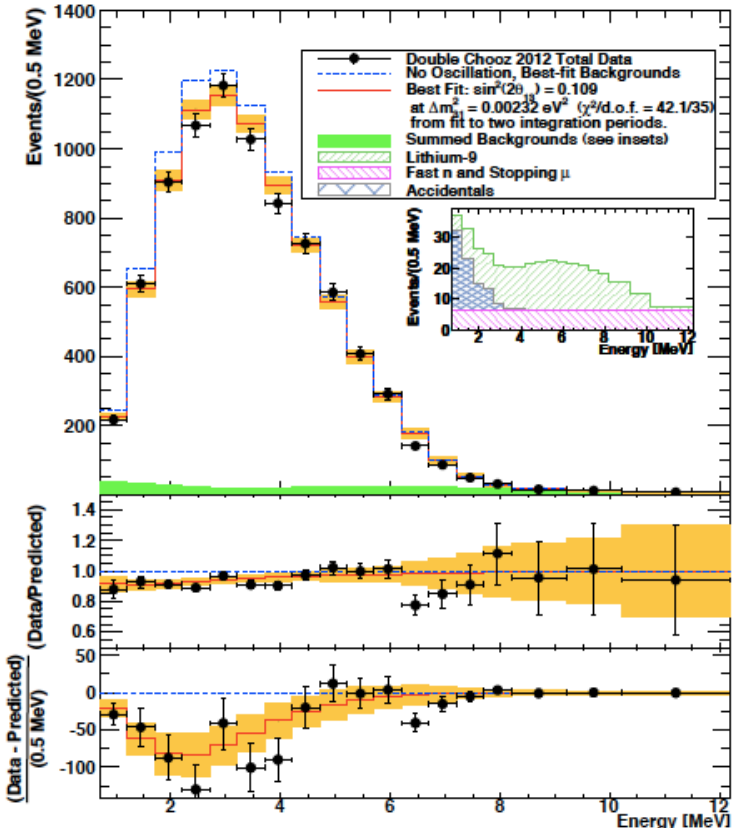

The Big Bang Theory (CBS)

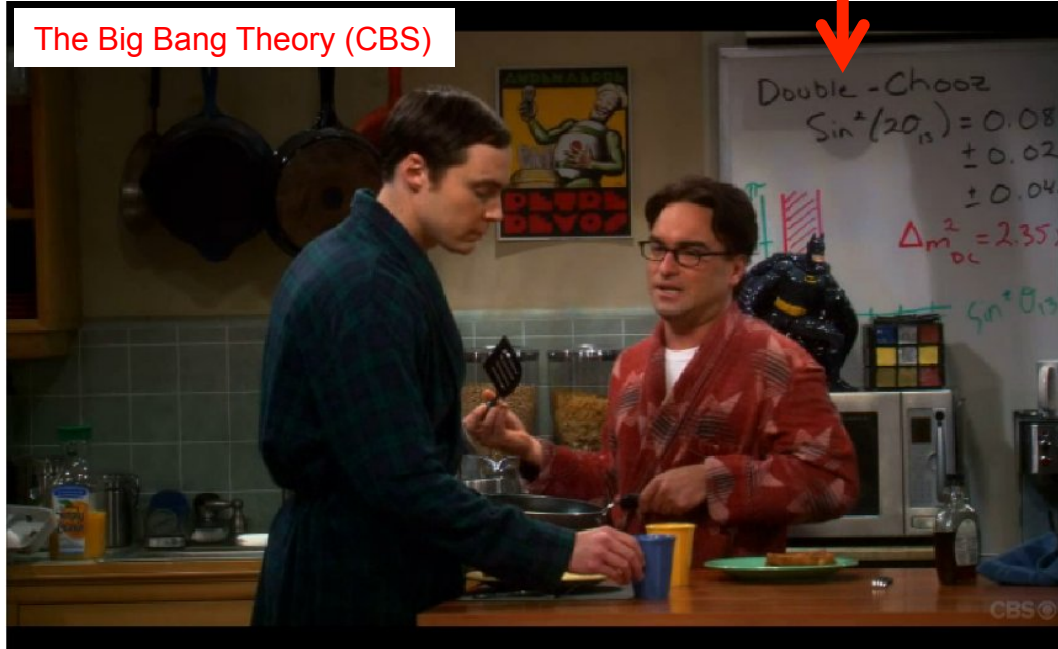

6. Double Chooz experiment

Reactor electron antineutrino disappearance

- Double Chooz, DayaBay and RENO experiments observed disappearance

This small disappearance may have sidereal time dependence?

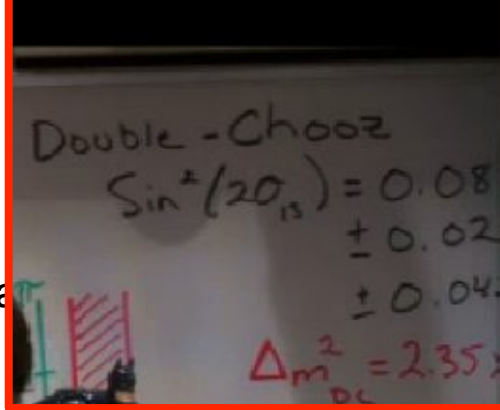

Double Chooz reactor neutrino candidate

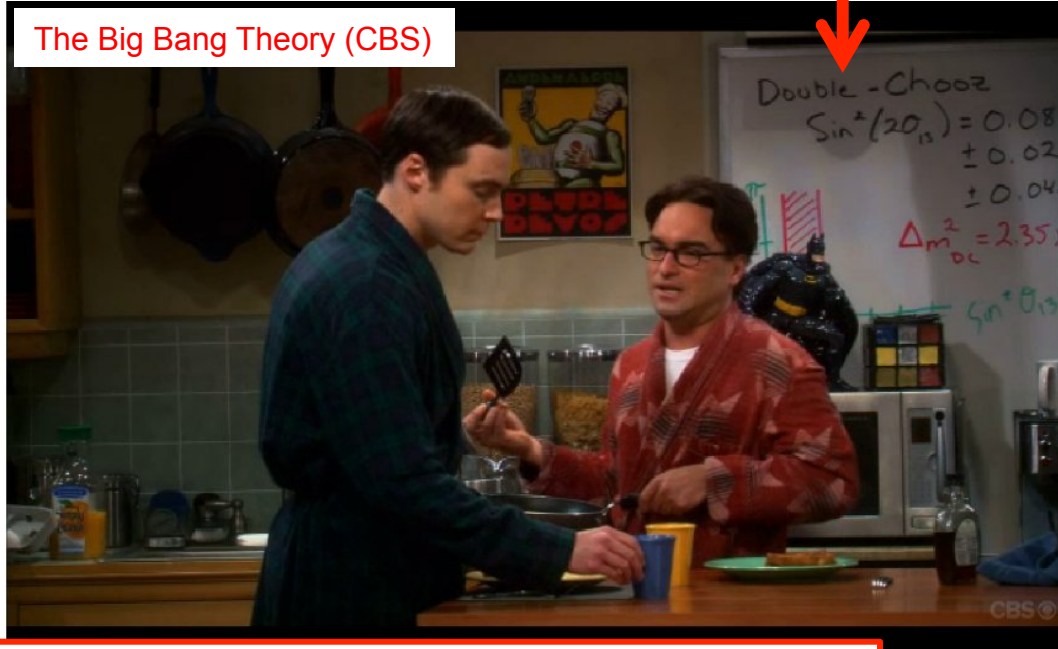
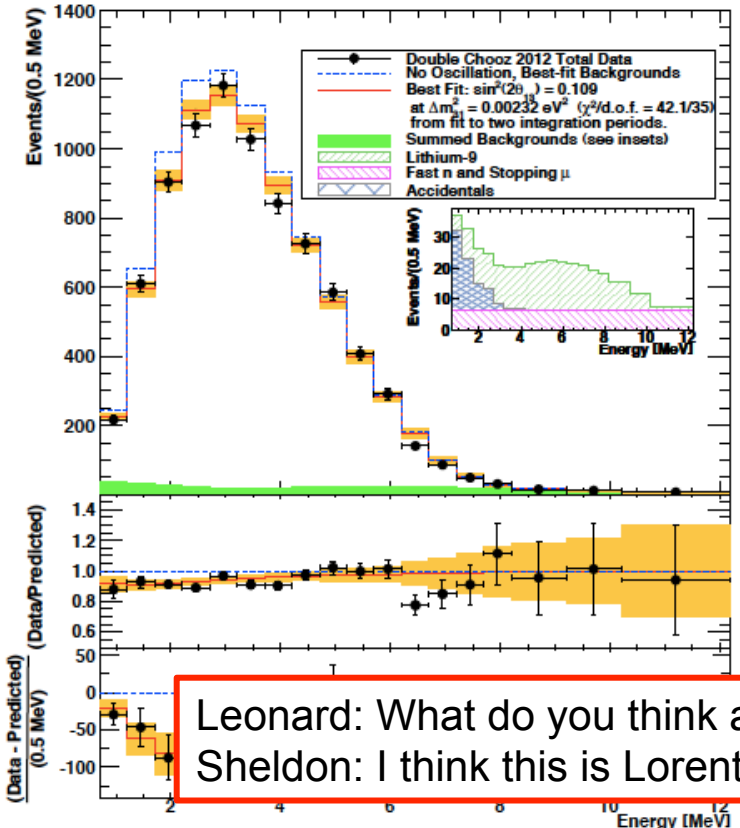

The Big Bang Theory (CBS)

Leonard: What do you think about the latest Double Chooz result?
 Sheldon: I think this is Lorentz violation..., check sidereal time dependence

6. Double Chooz experiment

So far, we have set limits on

- 1. $\nu_e \leftrightarrow \nu_\mu$ channel: LSND, MiniBooNE, MINOS ($<10^{-20}$ GeV)
- 2. $\nu_\mu \leftrightarrow \nu_\tau$ channel: MINOS, IceCube ($<10^{-23}$ GeV)

The last untested channel is $\nu_e \leftrightarrow \nu_\tau$

It is possible to limit $\nu_e \leftrightarrow \nu_\tau$ channel from reactor ν_e disappearance experiment

$$P(\nu_e \leftrightarrow \nu_e) = 1 - P(\nu_e \leftrightarrow \nu_\mu) - P(\nu_e \leftrightarrow \nu_\tau) \sim 1 - P(\nu_e \leftrightarrow \nu_\tau)$$

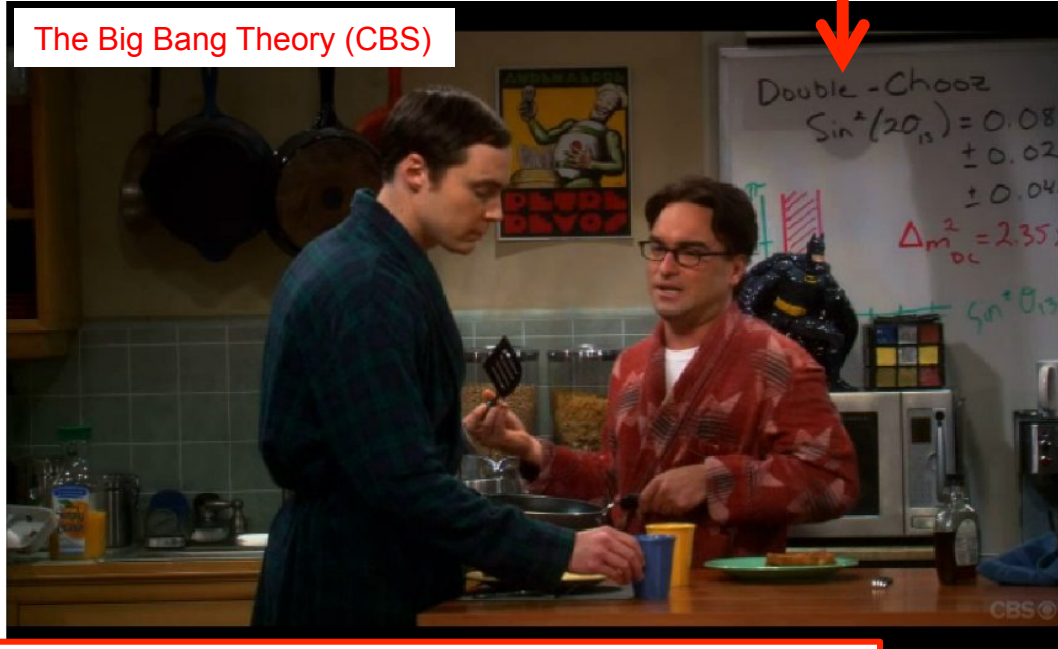
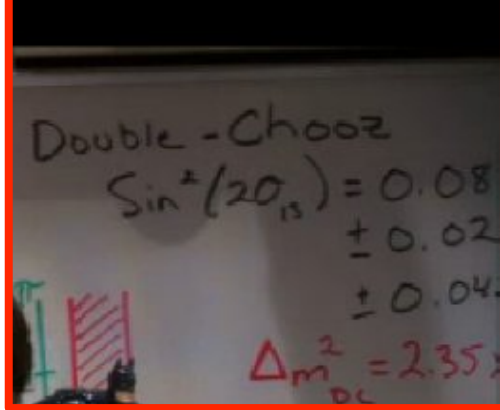

The Big Bang Theory (CBS)

Leonard: What do you think about the latest Double Chooz result?
 Sheldon: I think this is Lorentz violation..., check sidereal time dependence

6. Double Chooz experiment

So far, we have set limits on

1. $\nu_e \leftrightarrow \nu_\mu$ channel: LSND, MiniBooNE, MINOS ($<10^{-20}$ GeV)
2. $\nu_\mu \leftrightarrow \nu_\tau$ channel: MINOS, IceCube ($<10^{-23}$ GeV)

The last untested channel is $\nu_e \leftrightarrow \nu_\tau$

It is possible to limit $\nu_e \leftrightarrow \nu_\tau$ channel from reactor ν_e disappearance experiment

$$P(\nu_e \leftrightarrow \nu_e) = 1 - P(\nu_e \leftrightarrow \nu_\mu) - P(\nu_e \leftrightarrow \nu_\tau) \sim 1 - P(\nu_e \leftrightarrow \nu_\tau)$$

Small disappearance signal
prefers **sidereal time independent**
solution (flat)

We set limits in the e- τ sector for
the first time; $\nu_e \leftrightarrow \nu_\tau$ ($<10^{-20}$ GeV)

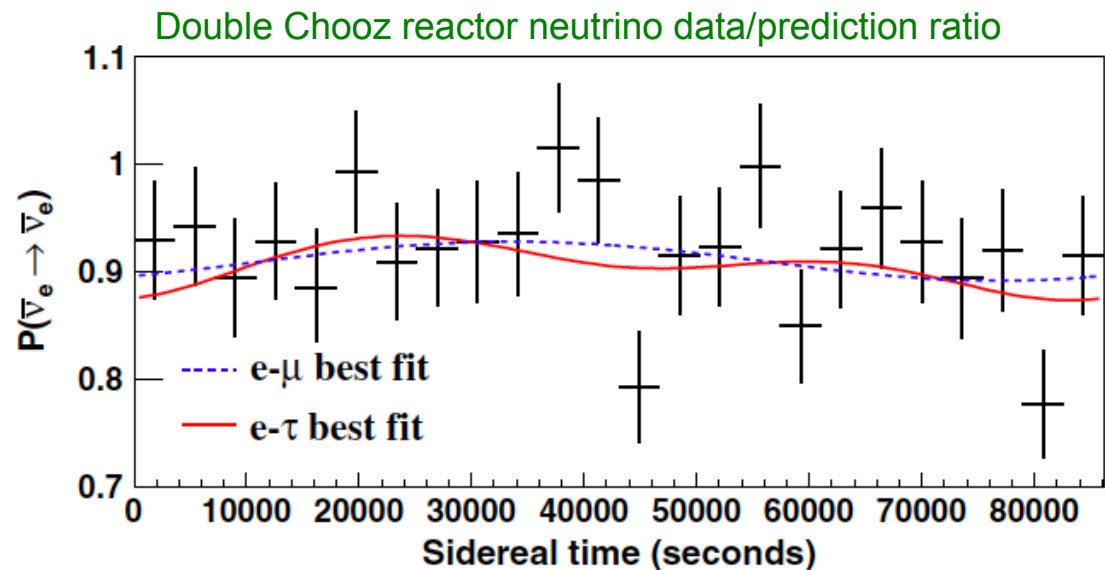

6. Double Chooz experiment

By this work, Lorentz violation is tested with all neutrino channels

Chance to see the Lorentz violation in terrestrial neutrino experiments will be very small

MiniBooNE
MINOS ND **Double Chooz** IceCube
MINOS FD

$d = 3$	Coefficient	$e\mu$	$e\tau$	$\mu\tau$
	$Re(a_L)^T$	10^{-20} GeV	10^{-19} GeV	–
	$Re(a_L)^X$	10^{-20} GeV	10^{-19} GeV	10^{-23} GeV
	$Re(a_L)^Y$	10^{-21} GeV	10^{-19} GeV	10^{-23} GeV
	$Re(a_L)^Z$	10^{-19} GeV	10^{-19} GeV	–
$d = 4$	Coefficient	$e\mu$	$e\tau$	$\mu\tau$
	$Re(c_L)^{XY}$	10^{-21}	10^{-17}	10^{-23}
	$Re(c_L)^{XZ}$	10^{-21}	10^{-17}	10^{-23}
	$Re(c_L)^{YZ}$	10^{-21}	10^{-16}	10^{-23}
	$Re(c_L)^{XX}$	10^{-21}	10^{-16}	10^{-23}
	$Re(c_L)^{YY}$	10^{-21}	10^{-16}	10^{-23}
	$Re(c_L)^{ZZ}$	10^{-19}	10^{-16}	–
	$Re(c_L)^{TT}$	10^{-19}	10^{-17}	–
	$Re(c_L)^{TX}$	10^{-22}	10^{-17}	10^{-27}
	$Re(c_L)^{TY}$	10^{-22}	10^{-17}	10^{-27}
	$Re(c_L)^{TZ}$	10^{-20}	10^{-16}	–

Recently, Super-Kamiokande collaboration published significantly better limits
 PRD91(2015)052003

1. Spontaneous Lorentz symmetry breaking
2. What is Lorentz and CPT violation?
3. Modern test of Lorentz violation
4. Lorentz violating neutrino oscillation
5. Test for Lorentz violation with MiniBooNE data
6. Test for Lorentz violation with Double Chooz data
7. **Extra-terrestrial ultra-high energy neutrinos**
8. Conclusion

7. Neutrino standard Model (ν SM)

This is the world data of neutrino oscillation

It looks majority of region is either accepted (positive signals) or excluded

But this is model dependent diagram, because it assumes **neutrino mass as phase**, and **mass mixing matrix elements as amplitude of neutrino oscillations**

What is model independent diagram look like?

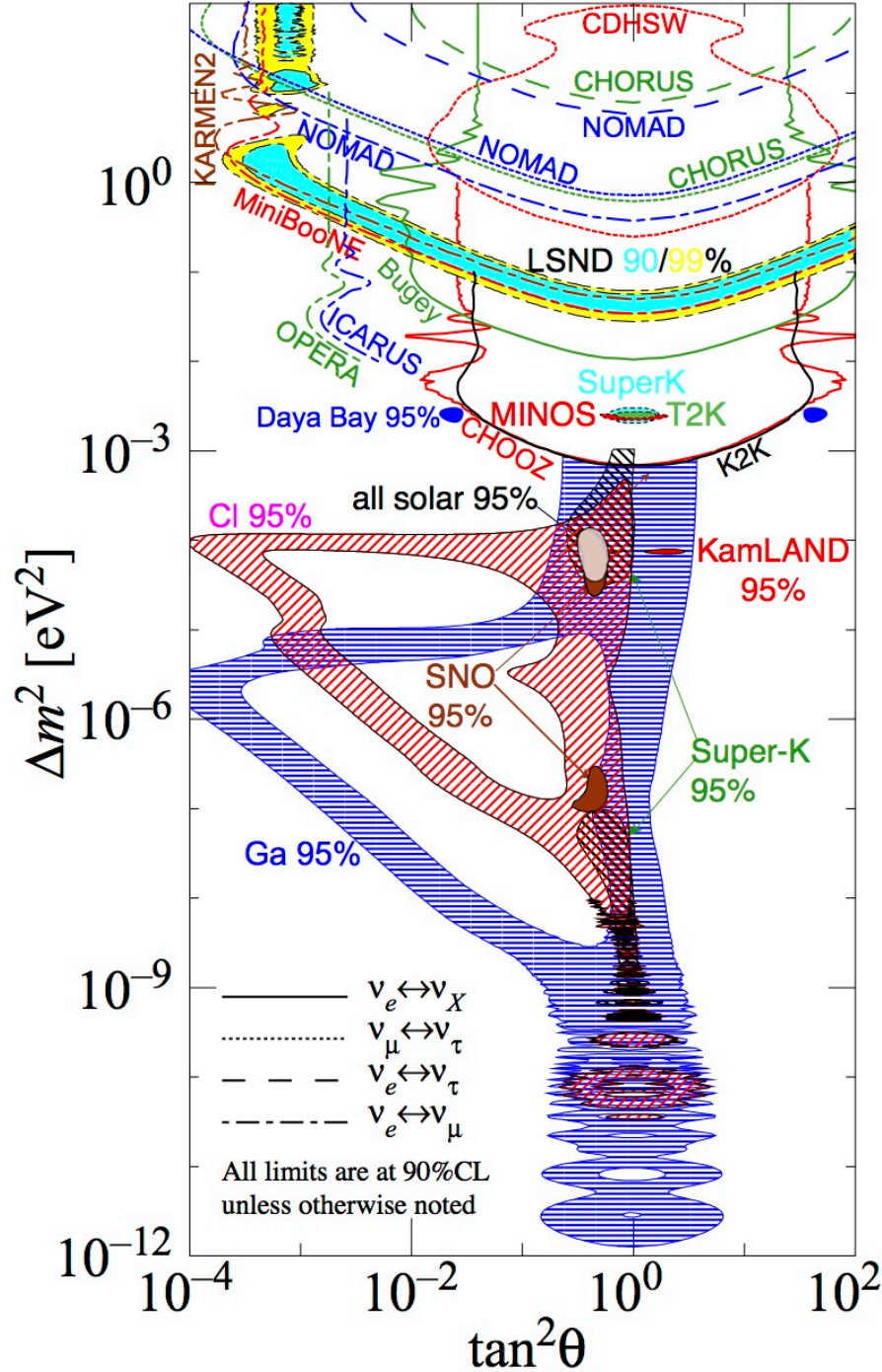

7. Lorentz violation with neutrino oscillation

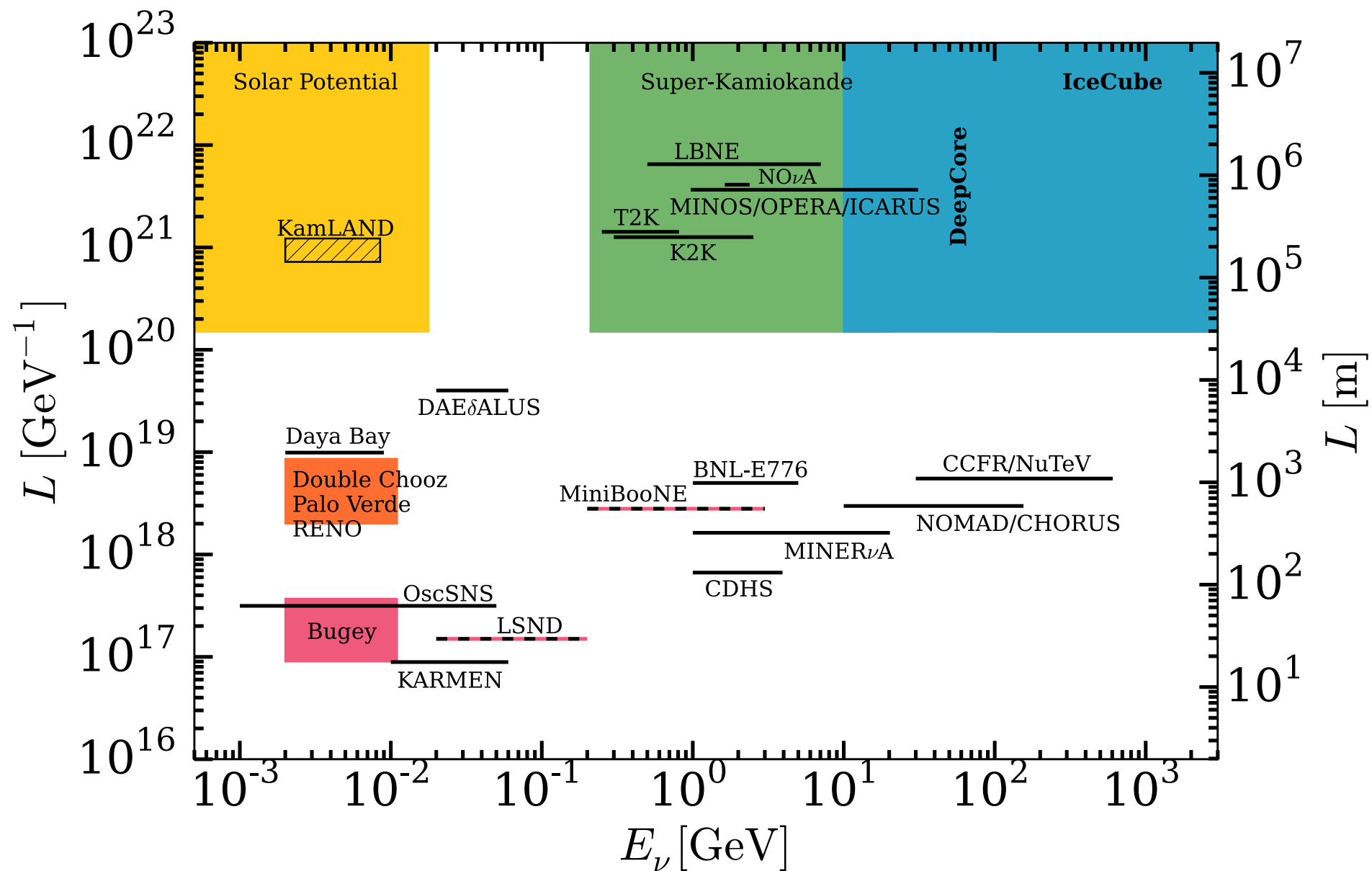

7. Lorentz violation with neutrino oscillation

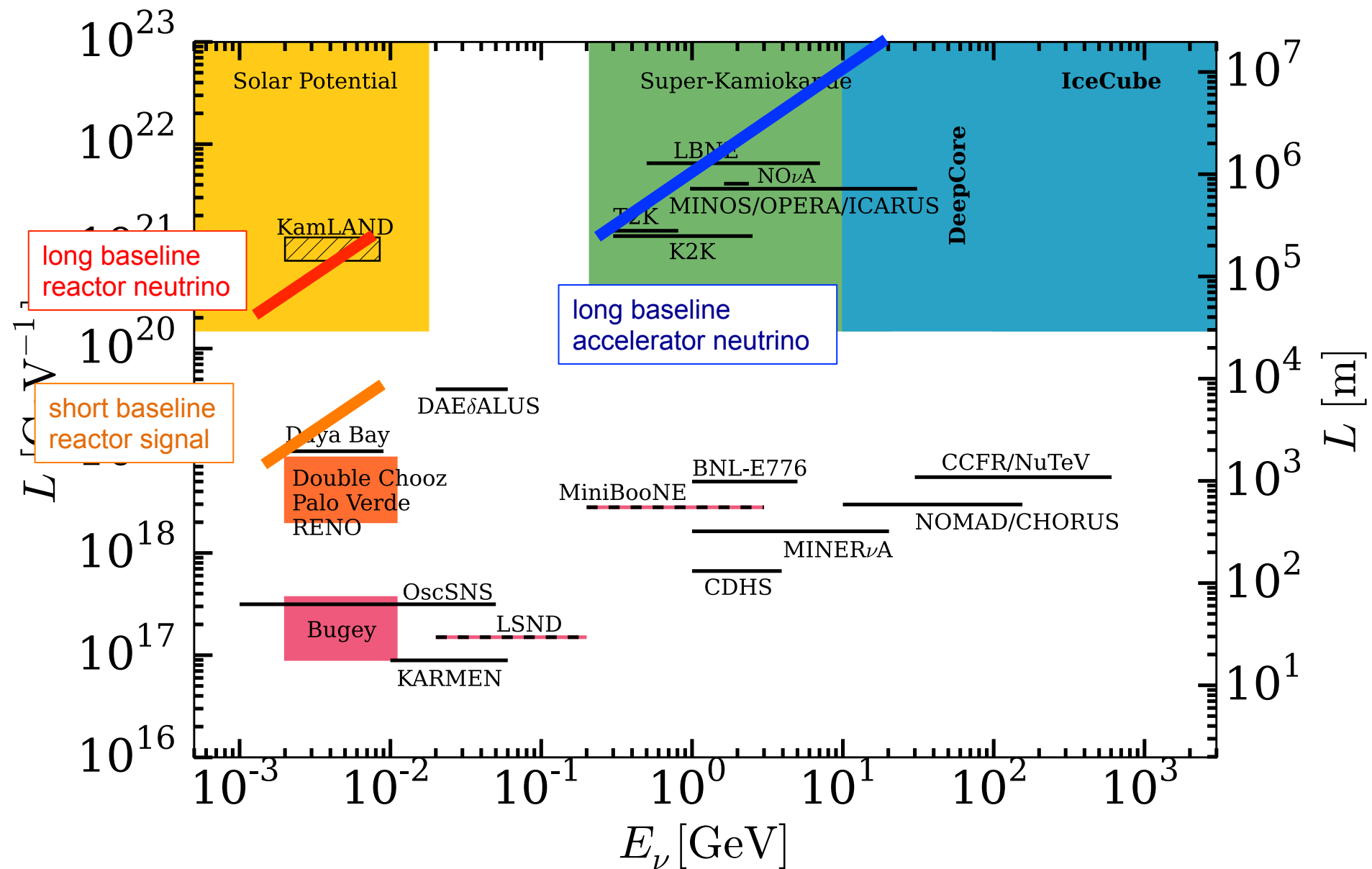

7. Lorentz violation with neutrino oscillation

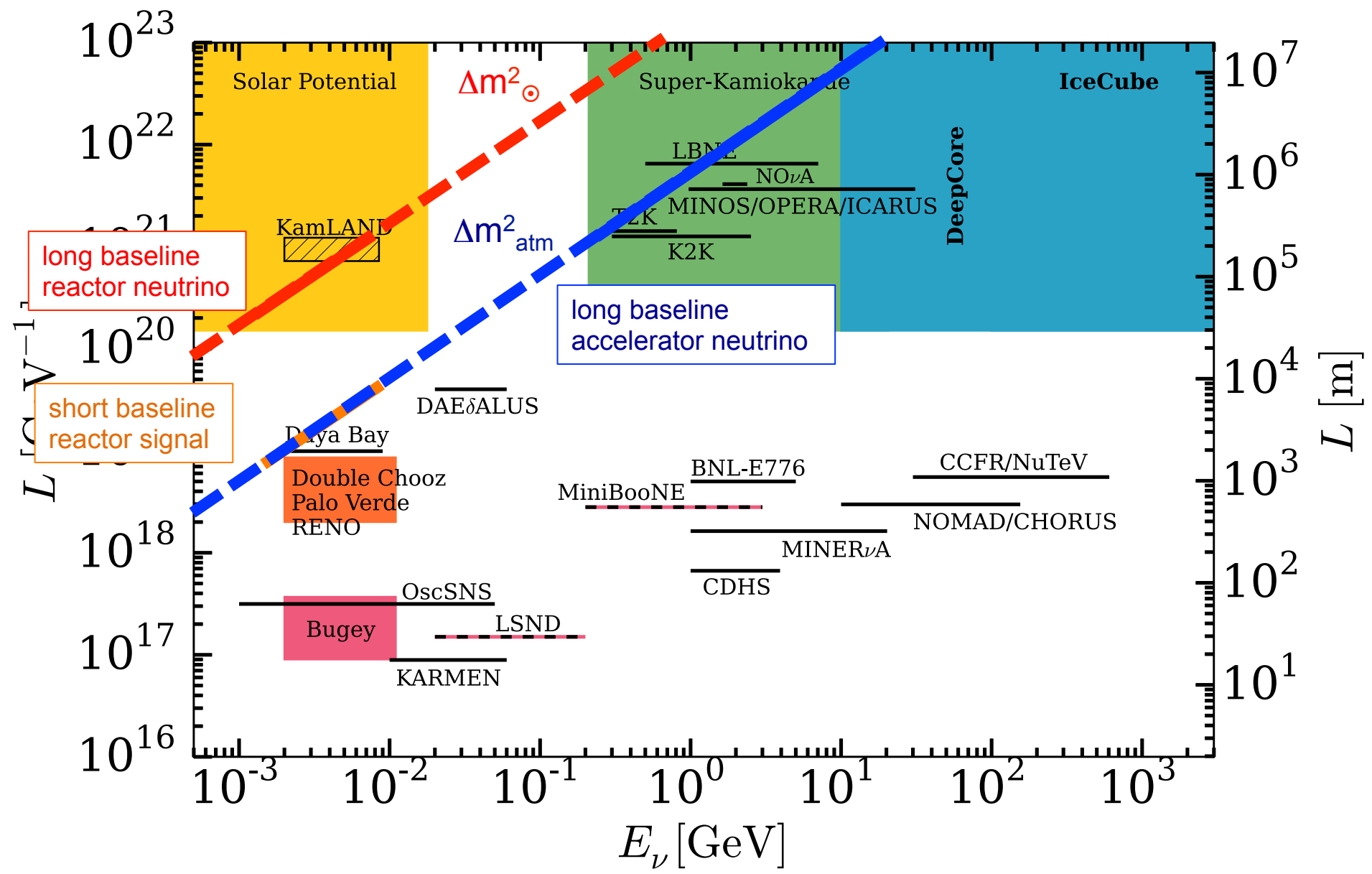

7. Lorentz violation with neutrino oscillation

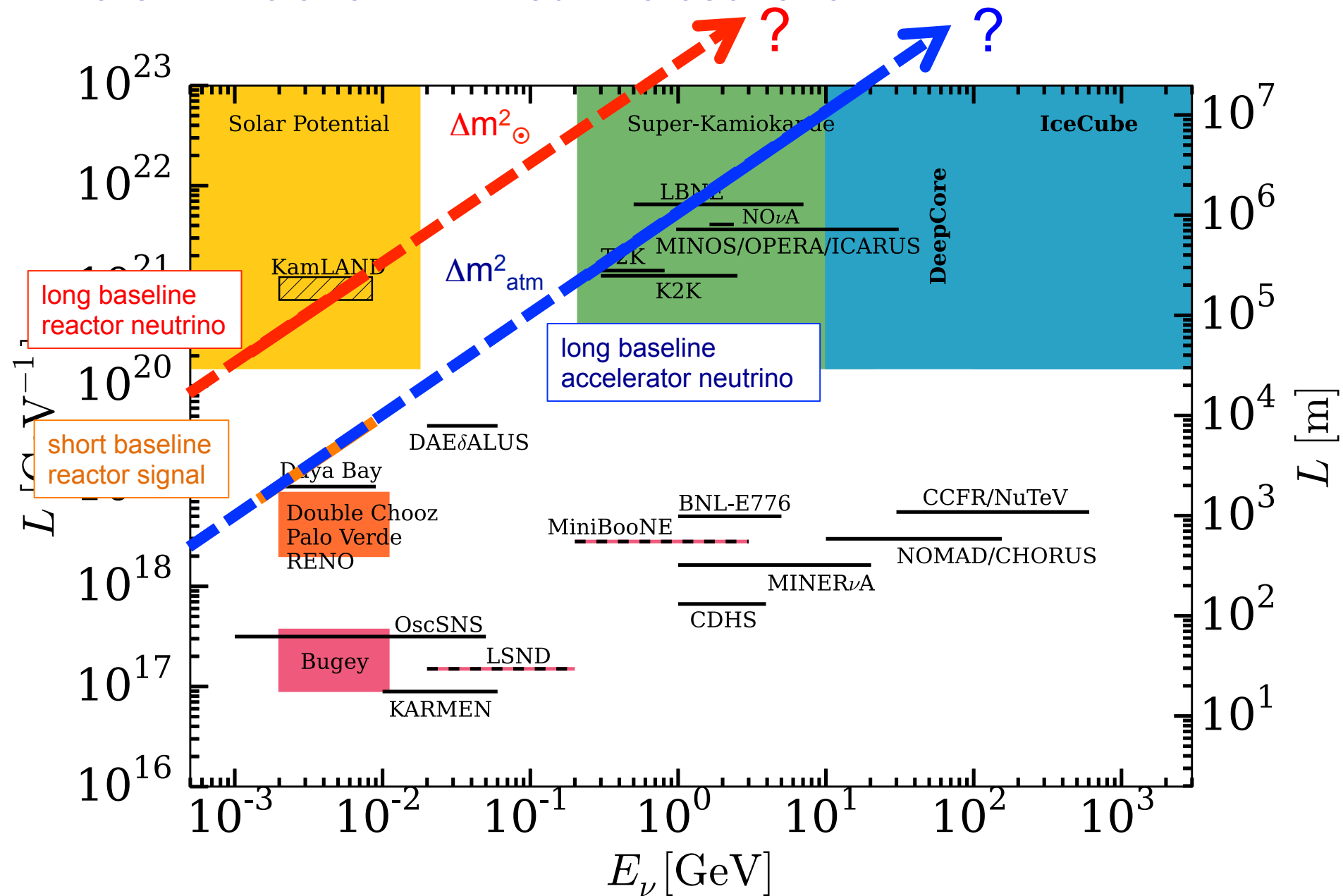

8. Lorentz violation with neutrino oscillation

extra galactic
neutrino potential

?
?

1Mpc (~Andromeda)

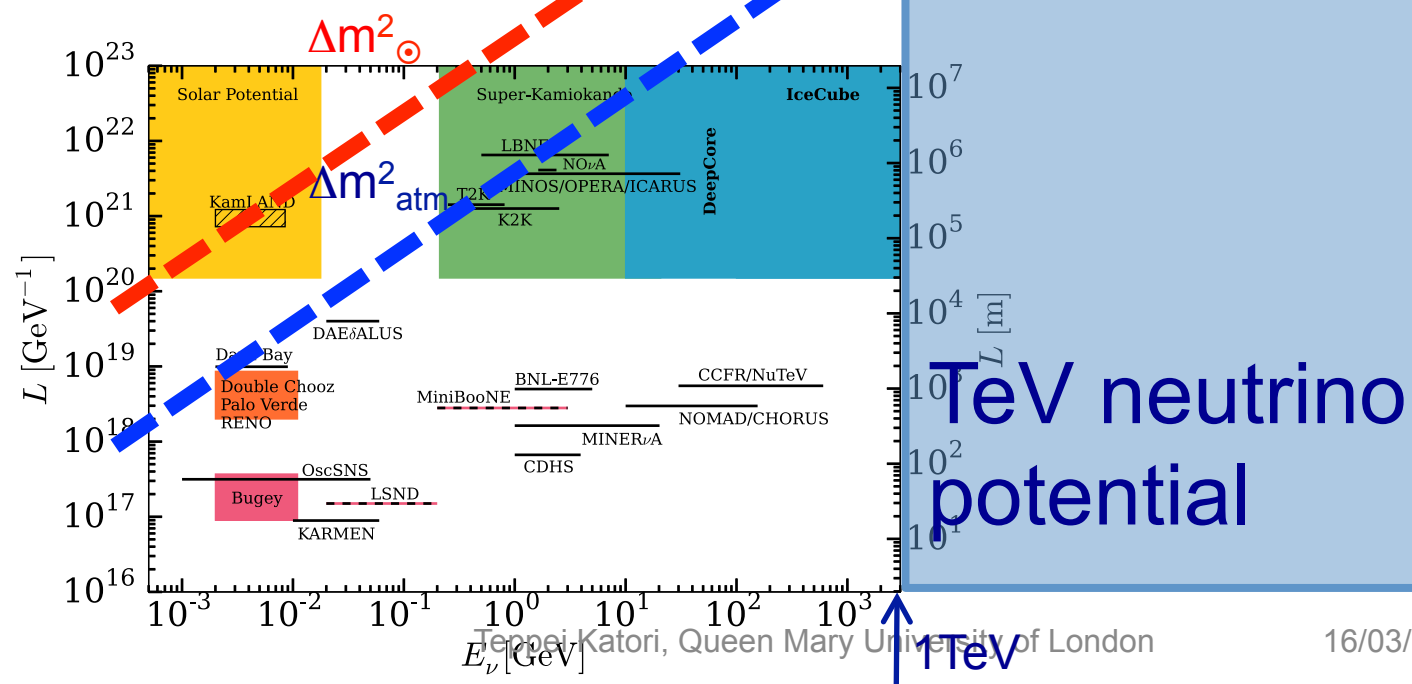

8. Lorentz violation with neutrino oscillation

extra galactic neutrino potential

?
?

1Mpc (~Andromeda)

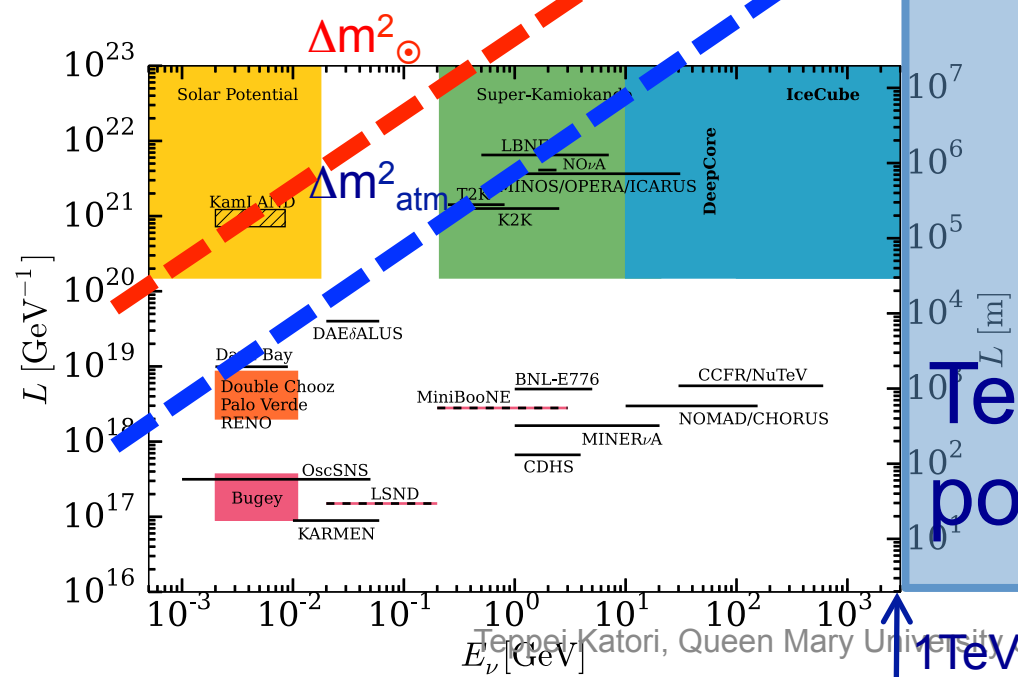

IceCube collaboration
PRL111(2013)021103

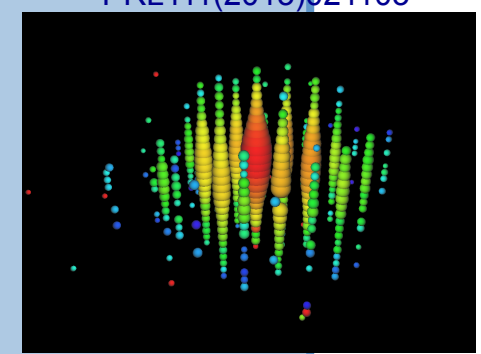

TeV neutrino potential



8. Lorentz violation with neutrino oscillation extra galactic

“Extraordinary discovery requires extraordinary evidence”
- Carl Sagan

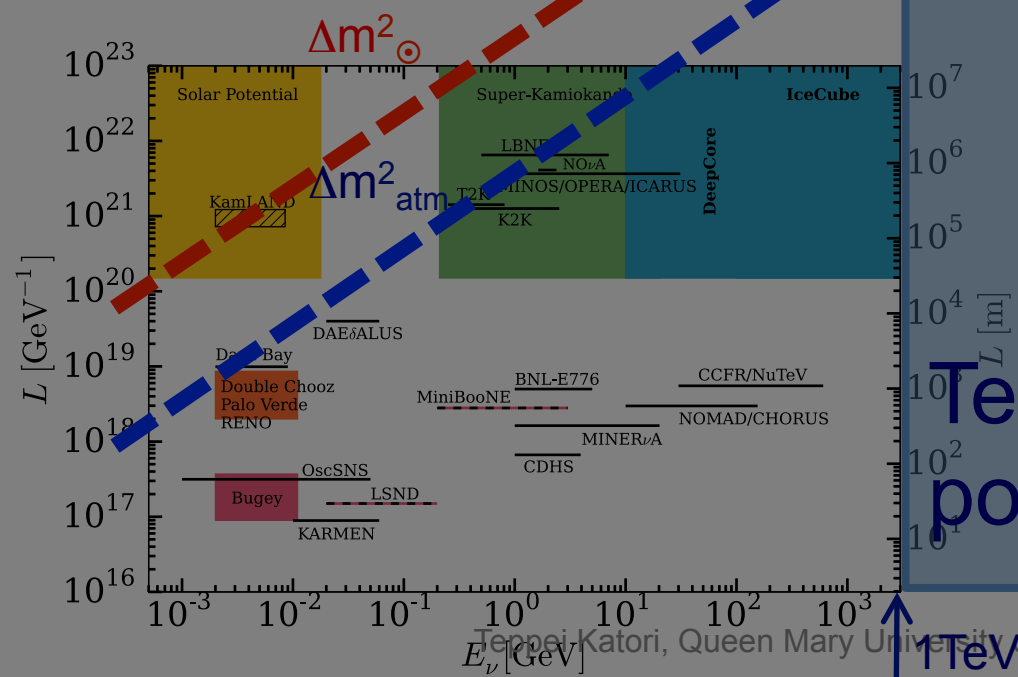

TeV neutrino potential



8. Lorentz violation with neutrino oscillation extra galactic



“Extraordinary discovery requires extraordinary evidence”

- Carl Sagan



“Extraordinary discovery requires extraordinary evidence from extraordinary particles with extraordinary energy and extraordinary scale”

- Teppei's reinterpretation of Carl Sagan

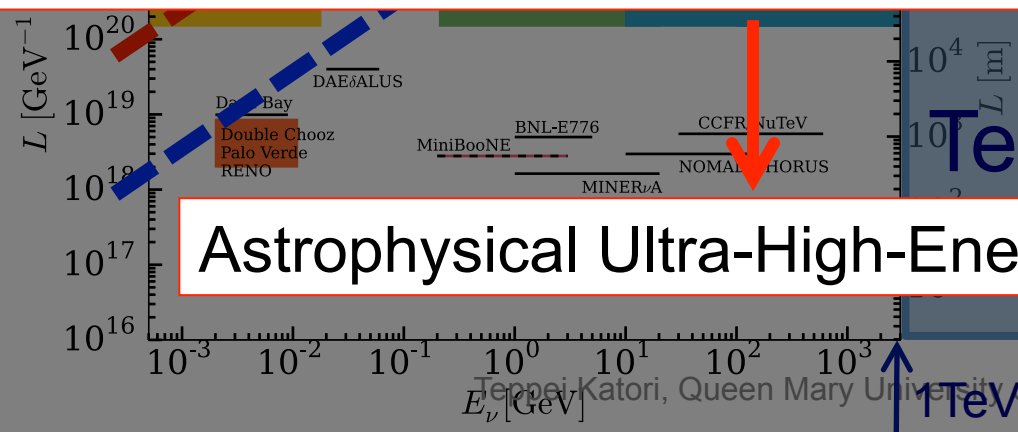

TeV neutrino

Astrophysical Ultra-High-Energy Neutrinos!



8. Lorentz violation with extra-terrestrial neutrinos

Combination of longer baseline and higher energy makes extra-terrestrial neutrino to be the most sensitive source of fundamental physics.

Vacuum Cherenkov radiation can limit new physics of neutrino up to 10^{-20}

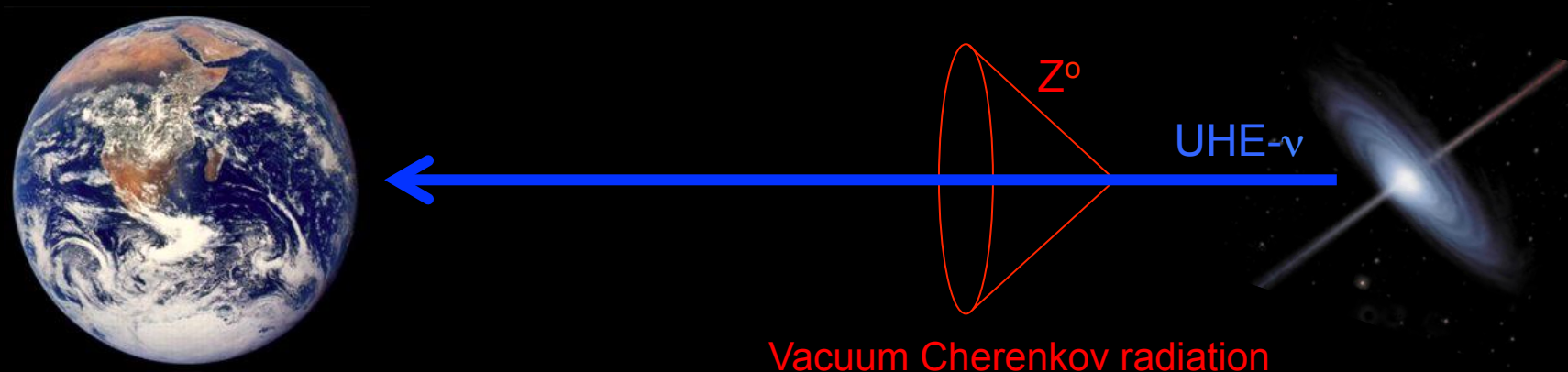

8. Lorentz violation with extra-terrestrial neutrinos

Combination of longer baseline and higher energy makes extra-terrestrial neutrino to be the most sensitive source of fundamental physics.

Vacuum Cherenkov radiation can limit new physics of neutrino up to 10^{-20}

However, the neutrino mixing properties of UHE neutrinos can push this limit further ($\sim 10^{-34}$). It is the most sensitive test of new physics (including Lorentz violation) with neutrinos.

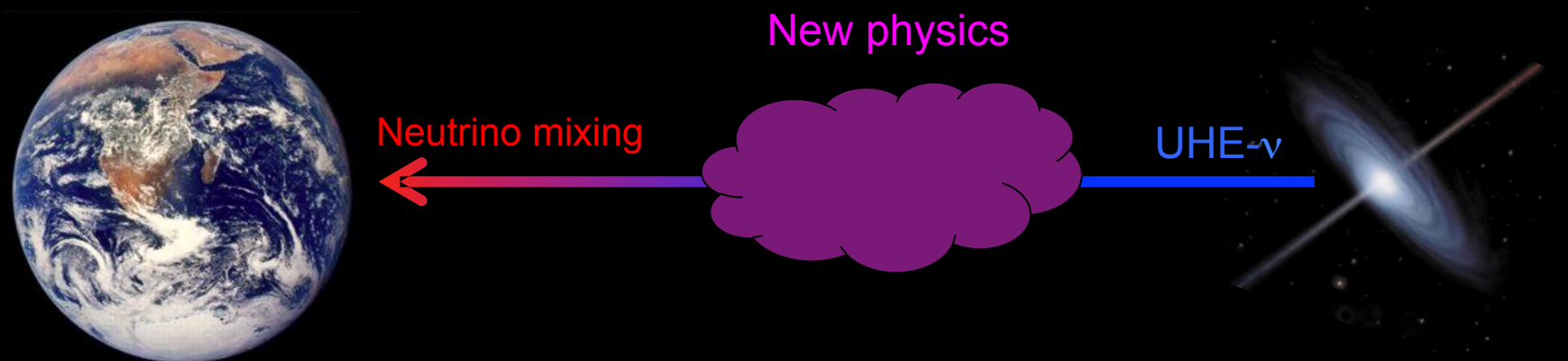

8. Neutrino flavour with new physics

Any new physics can end up in the effective Hamiltonian

$$h_{\text{eff}} = \frac{1}{2E} U^\dagger M^2 U + \sum_n \left(\frac{E}{\Lambda_n} \right)^n \tilde{U}_n^\dagger O_n \tilde{U}_n = V^\dagger \Delta V$$

neutrino oscillation formula

$$P_{\alpha \rightarrow \beta}(L) = 1 - 4 \sum_{i>j} \text{Re}(V_{\alpha i}^* V_{\beta i}^* V_{\alpha j} V_{\beta j}) \sin^2 \left(\frac{\Delta_{ij}}{2} L \right) + 2 \sum_{i>j} \text{Im}(V_{\alpha i}^* V_{\beta i}^* V_{\alpha j} V_{\beta j}) \sin(\Delta_{ij} L)$$

neutrino mixing formula

$$P_{\alpha \rightarrow \beta}(L \rightarrow \infty) \sim 1 - 2 \sum_{i>j} \text{Re}(V_{\alpha i}^* V_{\beta i}^* V_{\alpha j} V_{\beta j}) = \sum_i |V_{\alpha i}|^2 |V_{\beta i}|^2$$

Information of small contamination of new physics appears on **neutrino flavours**

At high energy, neutrino mass term is suppressed

→ (probably) mixing properties of the UHE neutrinos are the most sensitive method to look for new physics within particle physics

8. Standard flavour triangle diagram

There are 3 UHE neutrino production models

- i. pion decay dominant model, 1:2:0
- ii. electron neutrino dominant model, 1:0:0
- iii. muon neutrino dominant model, 0:1:0
- iv. tau neutrino dominant model, 0:0:1

Initial flavour ratio is modified on the Earth due to neutrino mixing

IceCube collaboration
PRL114(2015)171102

IceCube flavour triangle diagram

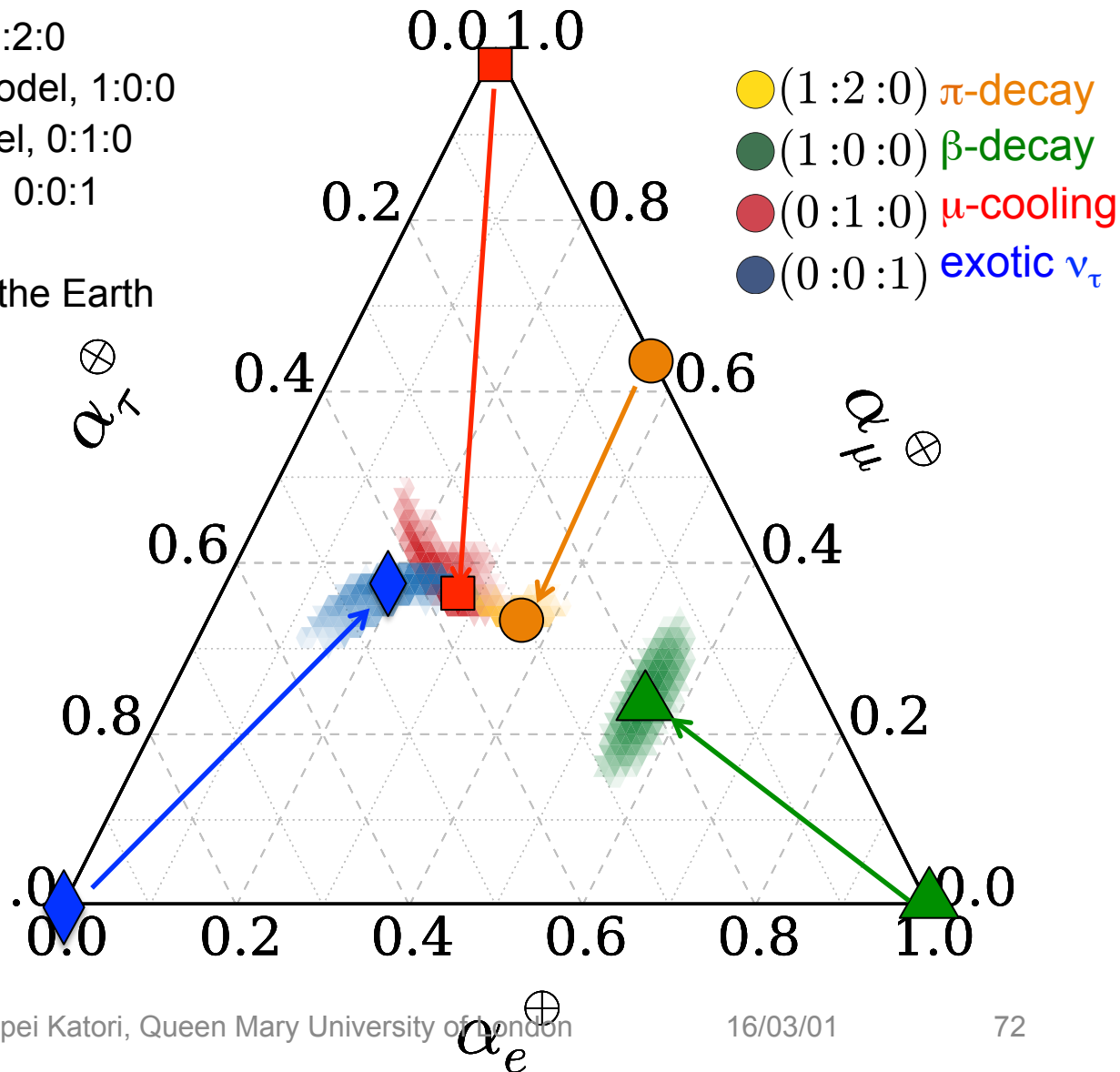
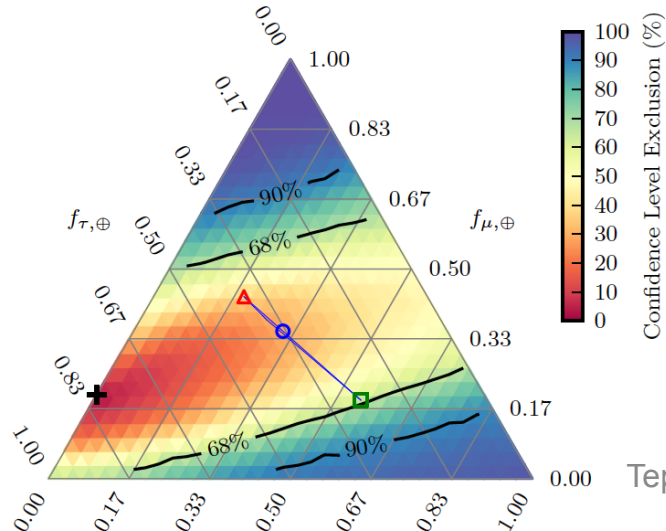

8. Standard flavour triangle diagram

There are 3 UHE neutrino production models

- i. pion decay dominant model, 1:2:0
- ii. electron neutrino dominant model, 1:0:0
- iii. muon neutrino dominant model, 0:1:0
- iv. tau neutrino dominant model, 0:0:1

Initial flavour ratio is modified on the Earth due to neutrino mixing

IceCube collaboration
PRL114(2015)171102

IceCube flavour triangle diagram

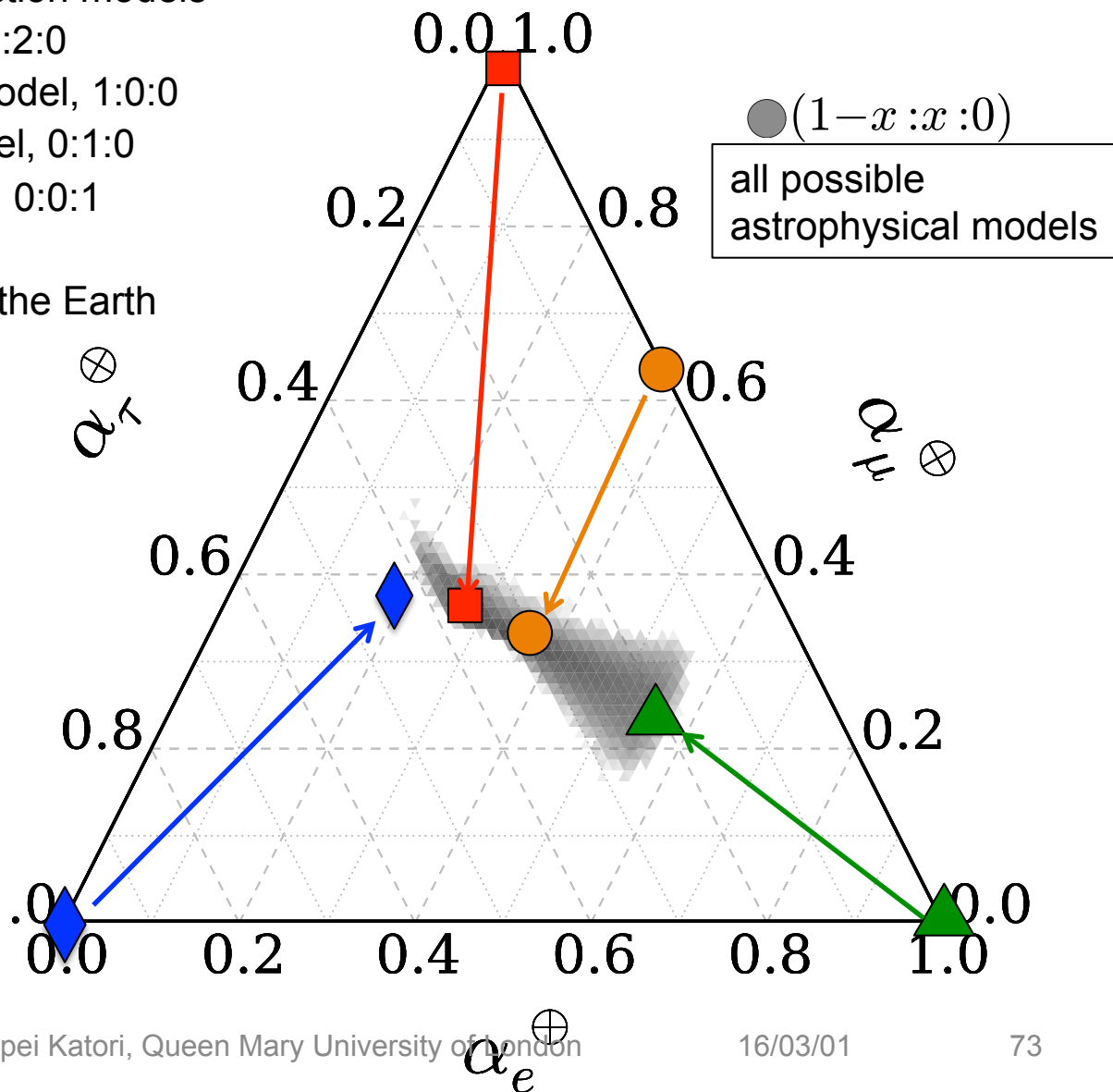
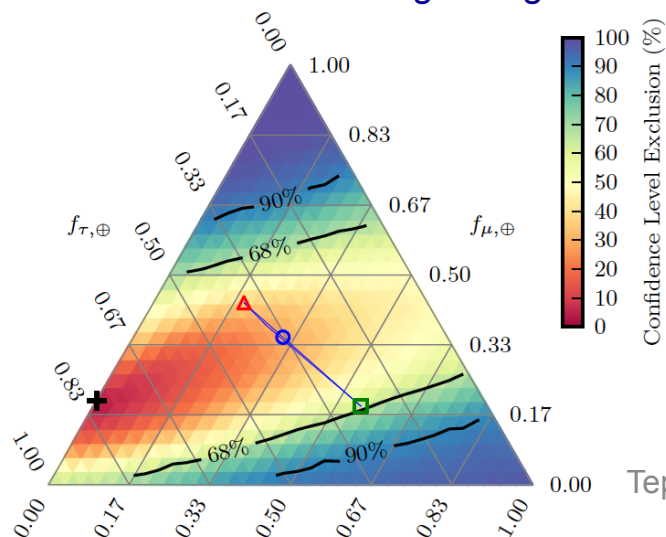

8. Neutrino flavour ratio with new physics

Any new physics can end up in the effective Hamiltonian

- neutrino mixing depends on energy
- there is strong initial flavour ratio dependency

An example Hamiltonian with new physics term
 ($\sim 10^{-26}$ GeV CPT odd Lorentz violation)

$$h_{eff} = \frac{1}{2E} \begin{pmatrix} m_{ee}^2 & m_{e\mu}^2 & m_{e\tau}^2 \\ m_{e\mu}^{2*} & m_{\mu\mu}^2 & m_{\mu\tau}^2 \\ m_{e\tau}^{2*} & m_{\mu\tau}^{2*} & m_{\tau\tau}^2 \end{pmatrix} + E \cdot \begin{pmatrix} 0 & 0 & 0 \\ 0 & 0 & c_{\mu\tau} \\ 0 & c_{\mu\tau} & c_{\tau\tau} \end{pmatrix}$$

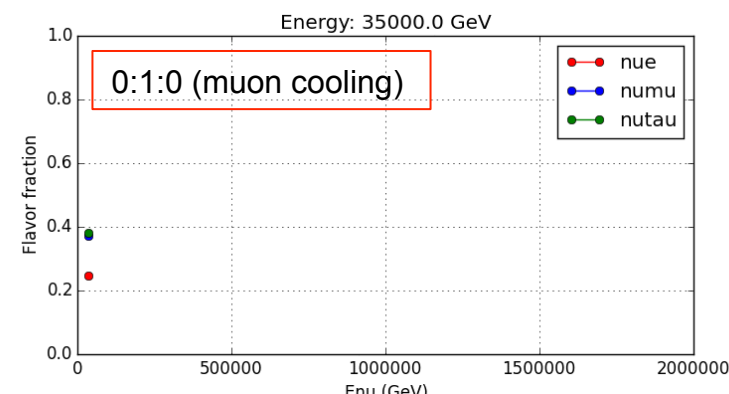
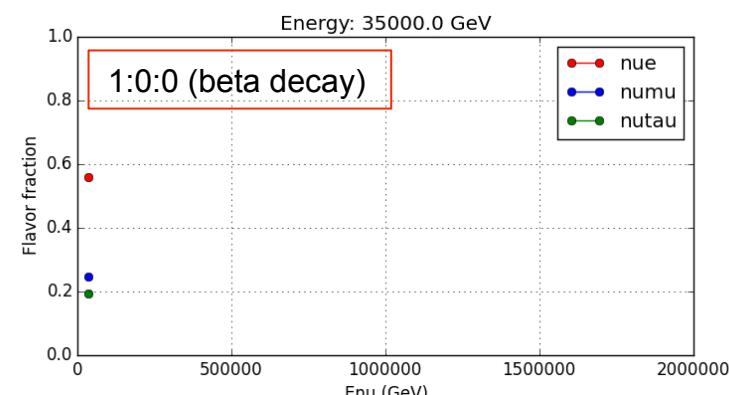
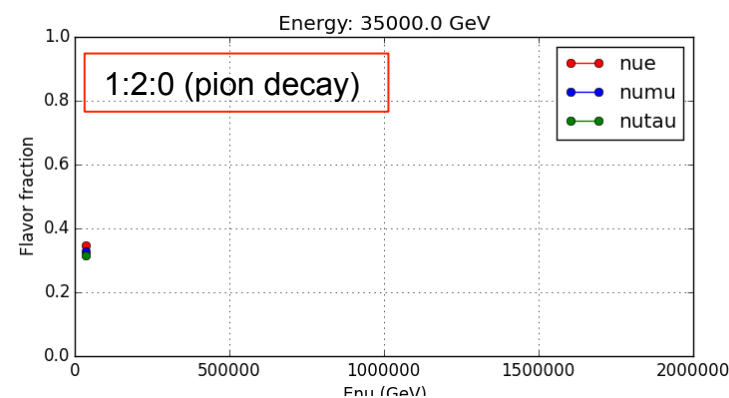

8. Neutrino flavour ratio with new physics

Any new physics can end up in the effective Hamiltonian

- neutrino mixing depends on energy
- there is strong initial flavour ratio dependency

Flavor triangle diagram is a convenient way to show these models.

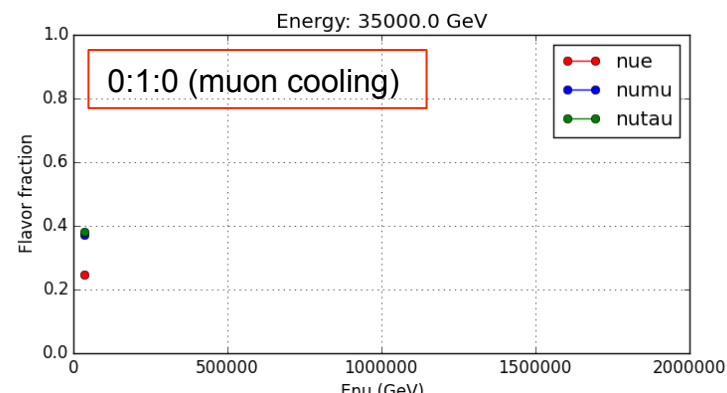
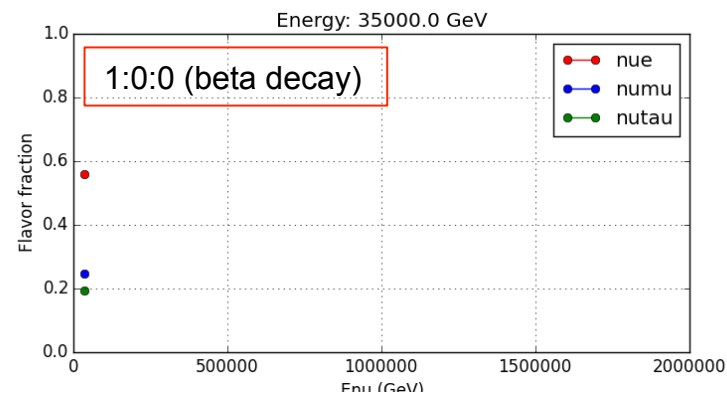
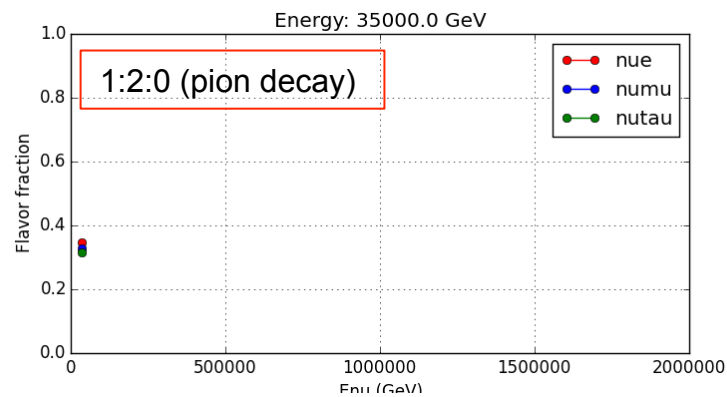
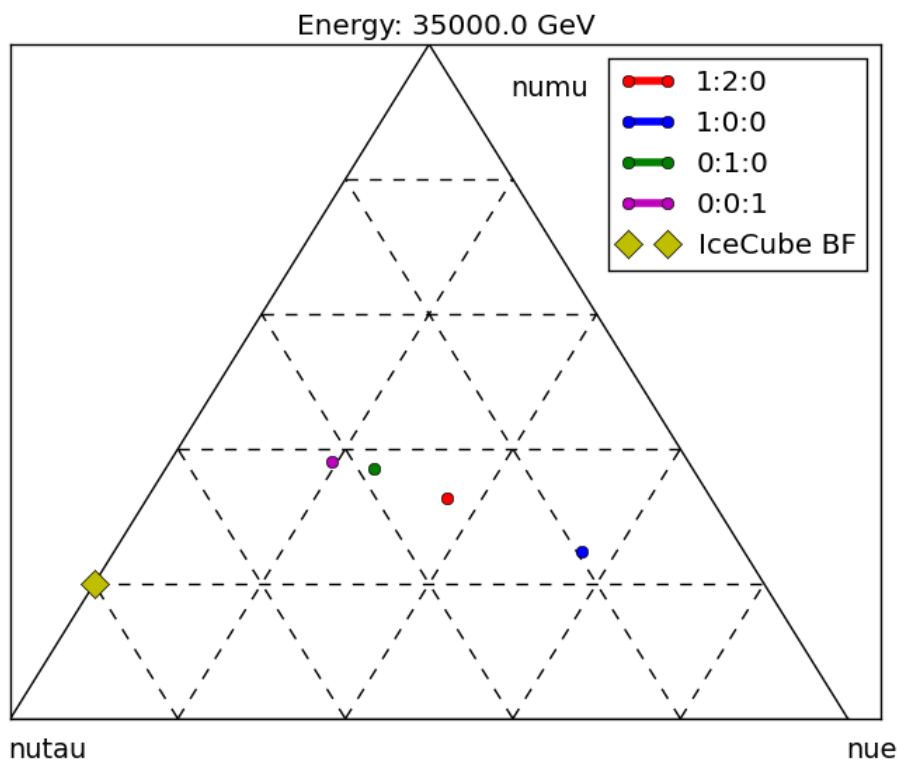

8. Flavour triangle histogram

However, we don't observe flavour ratio with function of energy
→ neutrino flux model ($\sim E^{-2}$) is convoluted

Also, there are many possible models
→ flavour triangle histogram

We follow the anarchic sampling scheme to choose the new physics model, and the model density is shown as a histogram on the triangle diagram.

$$d\tilde{U} = ds_{12}^2 \wedge dc_{13}^4 \wedge ds_{23}^2 \wedge d\delta$$

Large Lorentz violation → observed flavour ratio can be many option

Small Lorentz violation → only tiny deviation from the standard value is possible

8. Flavour triangle histogram

Exotic models can make variety of flavour ratios, but not every flavour ratio is possible.

$$h_{eff} = \frac{1}{2E} \begin{pmatrix} m_{ee}^2 & m_{e\mu}^2 & m_{e\tau}^2 \\ m_{e\mu}^{2*} & m_{\mu\mu}^2 & m_{\mu\tau}^2 \\ m_{e\tau}^{2*} & m_{\mu\tau}^{2*} & m_{\tau\tau}^2 \end{pmatrix} + \begin{pmatrix} a_{ee} & a_{e\mu} & a_{e\tau} \\ a_{e\mu}^* & a_{\mu\mu} & a_{\mu\tau} \\ a_{e\tau}^* & a_{\mu\tau}^* & a_{\tau\tau} \end{pmatrix}$$

n=0 operator new physics

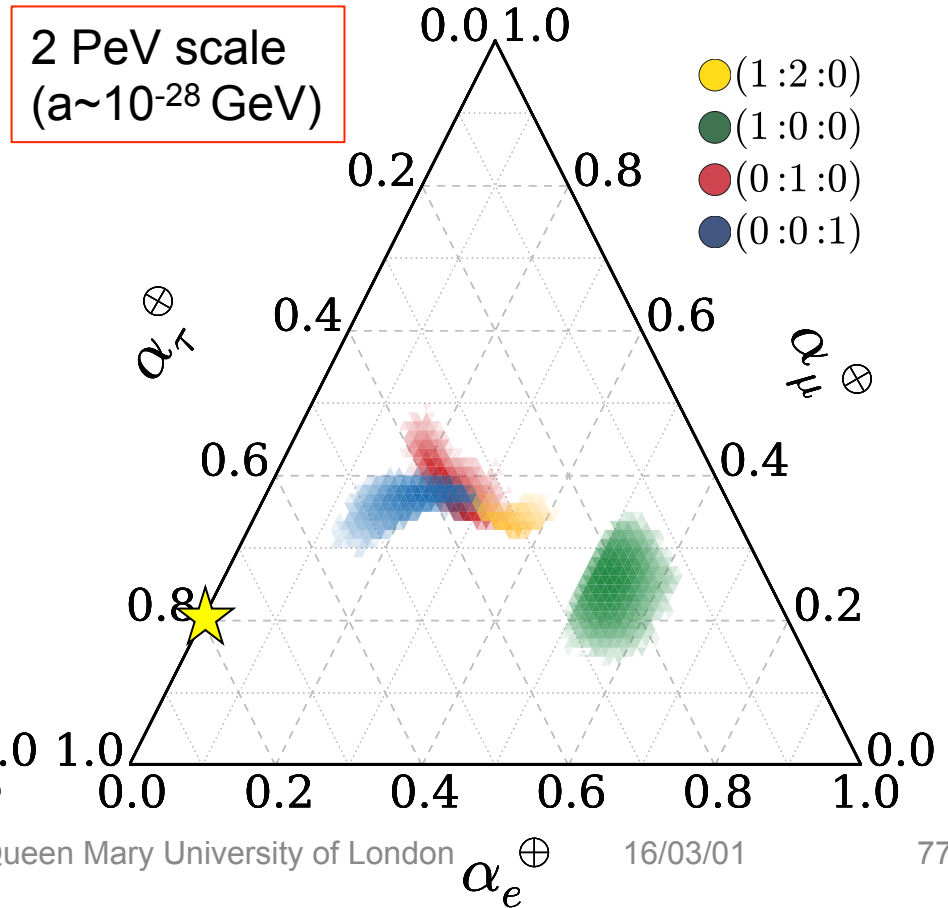
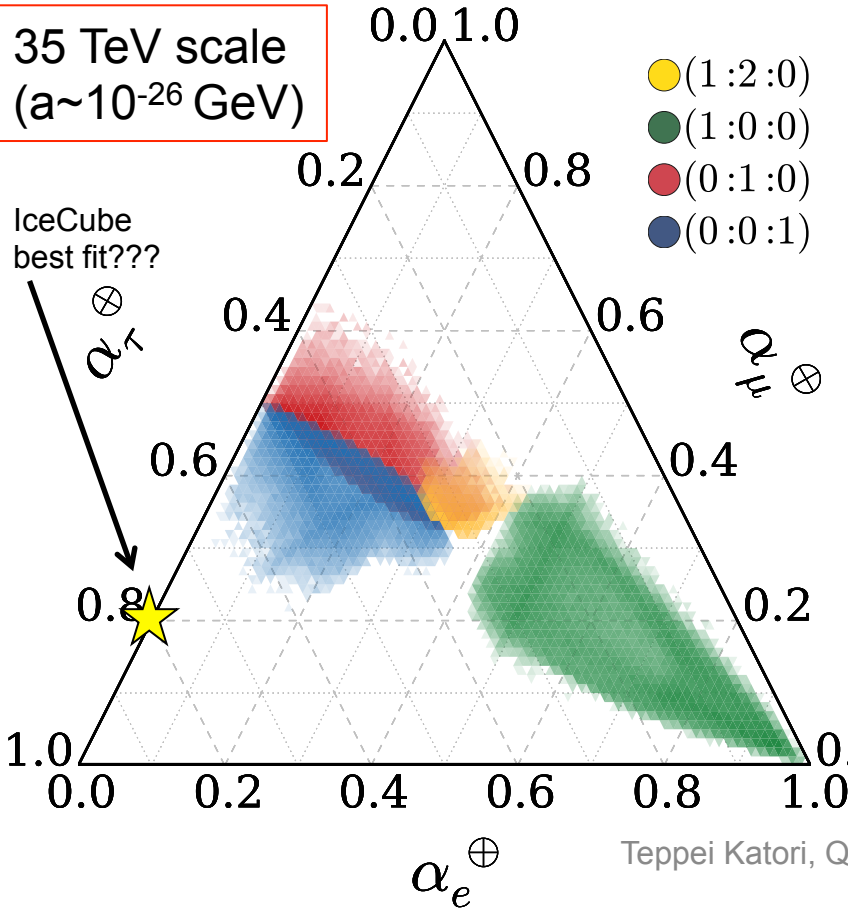

8. Flavour triangle histogram

Exotic models can make variety of flavour ratios, but not every flavour ratio is possible.

$$h_{eff} = \frac{1}{2E} \begin{pmatrix} m_{ee}^2 & m_{e\mu}^2 & m_{e\tau}^2 \\ m_{e\mu}^{2*} & m_{\mu\mu}^2 & m_{\mu\tau}^2 \\ m_{e\tau}^{2*} & m_{\mu\tau}^{2*} & m_{\tau\tau}^2 \end{pmatrix} + E \cdot \begin{pmatrix} c_{ee} & c_{e\mu} & c_{e\tau} \\ c_{e\mu}^* & c_{\mu\mu} & c_{\mu\tau} \\ c_{e\tau}^* & c_{\mu\tau}^* & c_{\tau\tau} \end{pmatrix}$$

Dimension-4 operator new physics

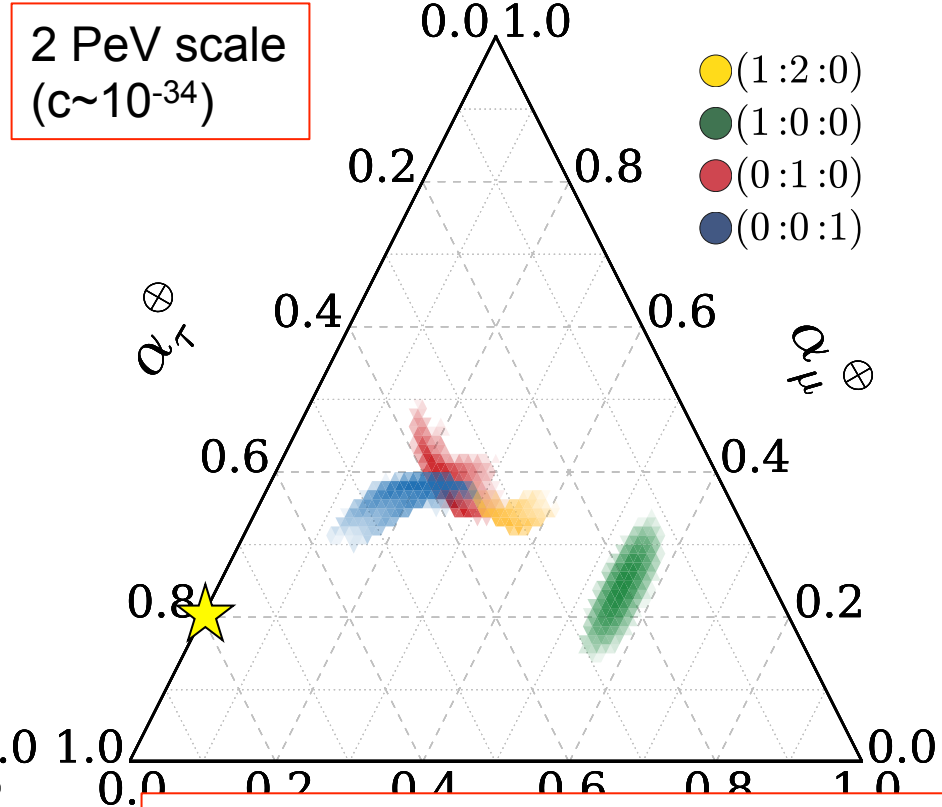
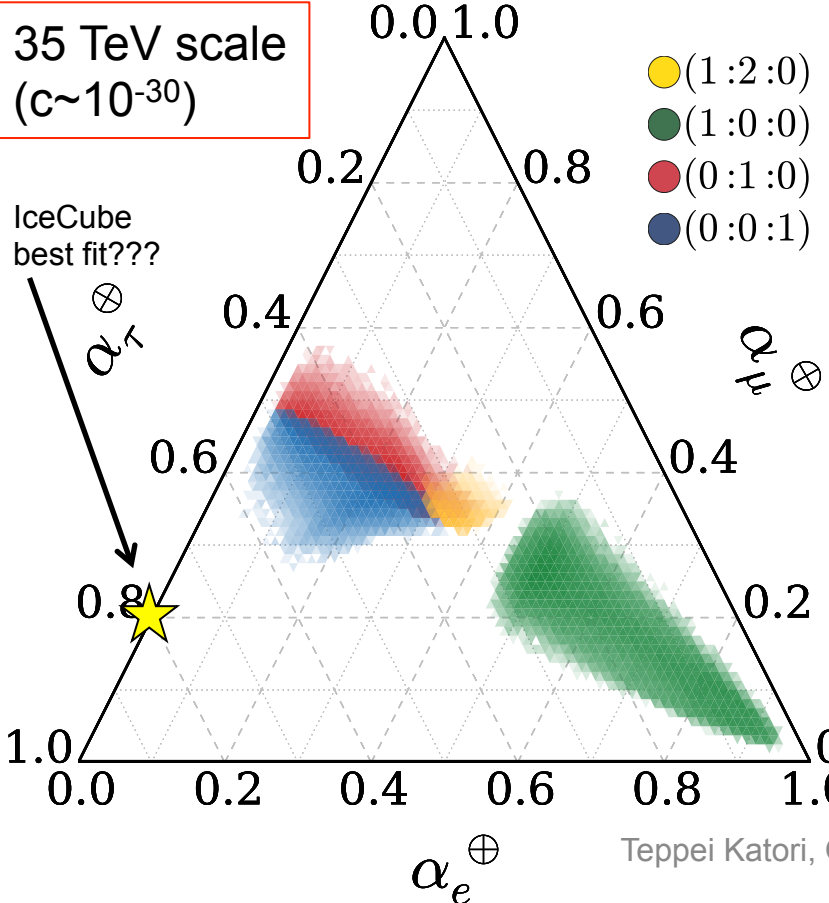

The flavour ratio is the most powerful tool to explore any new physics within particle physics

8. Flavour triangle by IceCube

Flavor ratio is sensitive with analysis method...

There is very shallow χ^2 min from ν_e -dominant to ν_τ -dominant solutions. Assumption of primary flux change the interpretation of data (absence of “Glashow resonance” events \rightarrow cascade events are dominated by ν_τ ? etc)

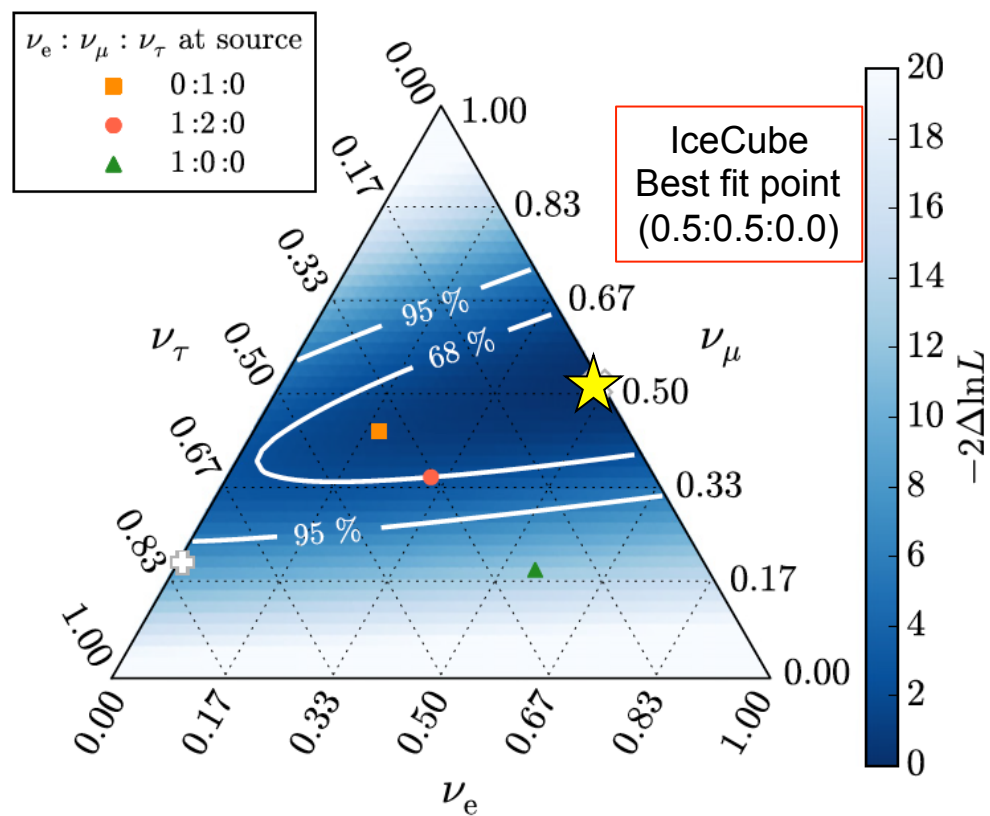
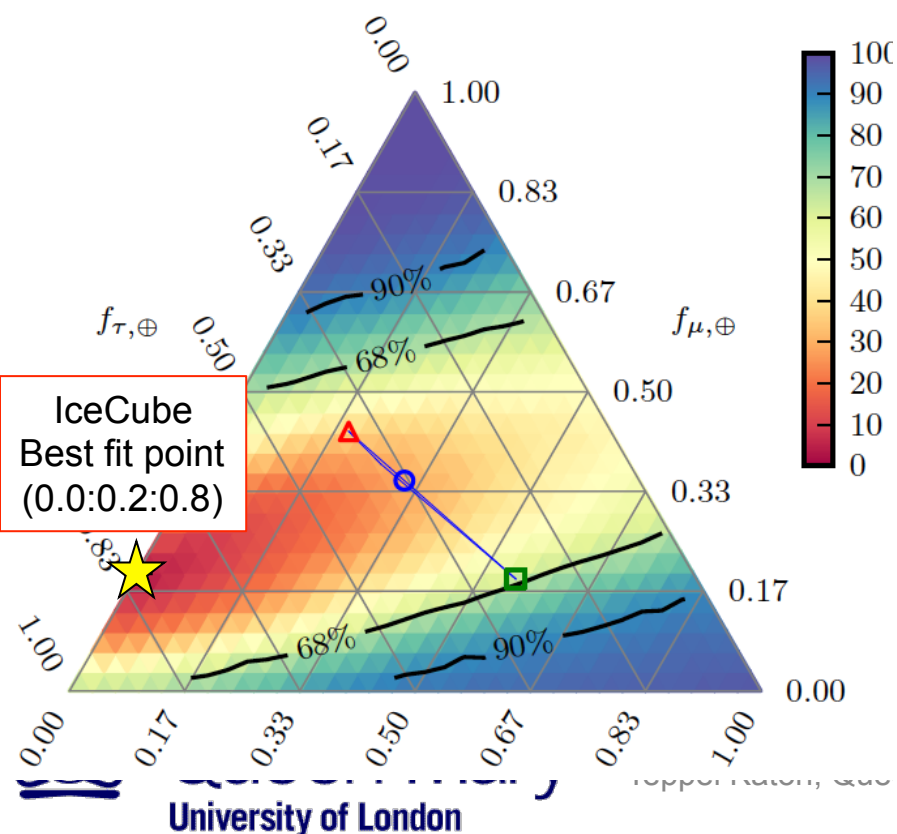

8. IceCube-Gen2

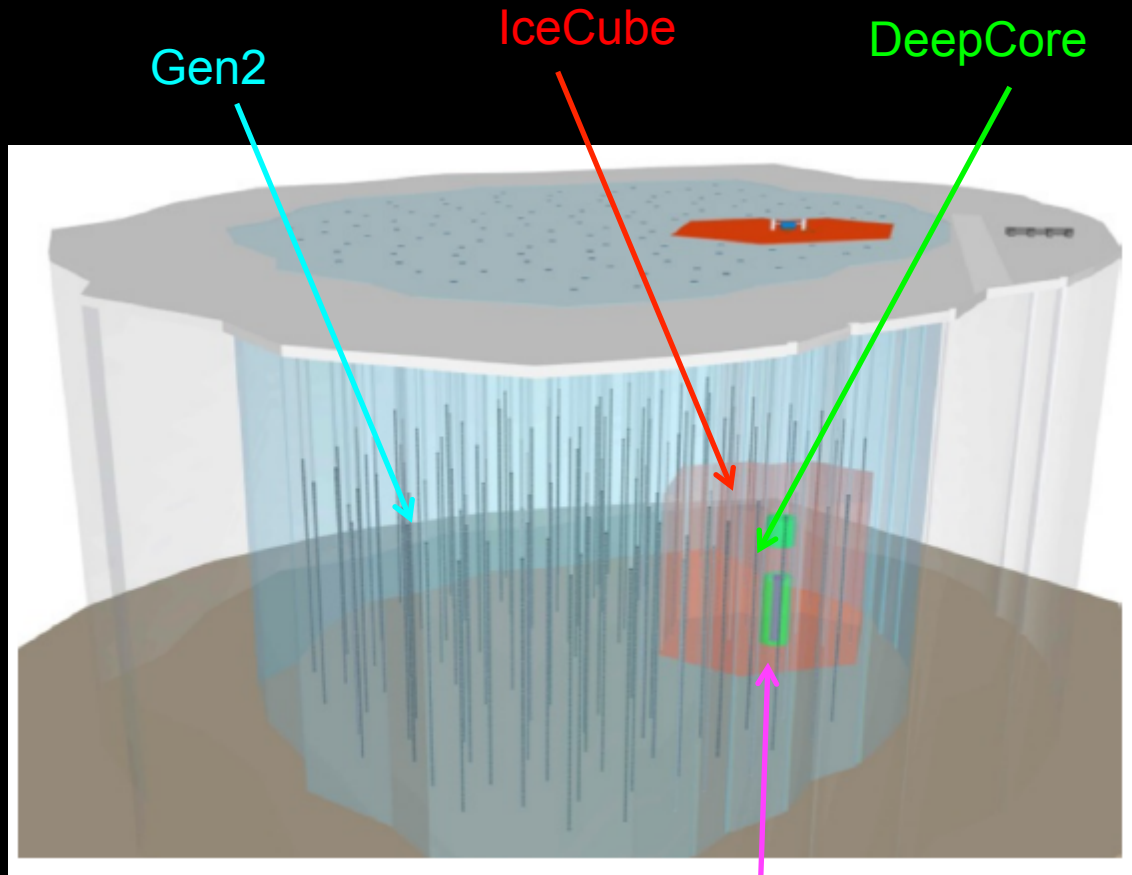

Bigger **IceCube** and denser **DeepCore** can push their physics

Gen2

Larger string separations to cover larger area

PINGU

Smaller string separation to achieve lower energy threshold for neutrino mass hierarchy measurement

IceCube-Gen2 collaboration meeting (May 1, 2015)



PINGU

The proposal will be submitted to NSF (UK members: Manchester, Oxford, Queen Mary)



Conclusion

Lorentz and CPT violation has been shown to occur in Planck-scale theories.

There is a world wide effort to test Lorentz violation with various state-of-the-art technologies.

MiniBooNE, MINOS, IceCube, Double Chooz, and Super-Kamiokande set stringent limits on Lorentz violation in neutrino sector in terrestrial level.

Extra-terrestrial neutrinos from IceCube are one of the most sensitive tool to test fundamental physics, such as Lorentz violation.

Thank you for your attention!



backup

2. Comment: Is there preferred frame?

As we see, all observers are related with observer's Lorentz transformation, so there is no special "preferred" frame (all observer's are consistent)

But there is a frame where universe looks isotropic even with a Lorentz violating vector field. You may call that is the "preferred frame", and people often speculate the frame where CMB looks isotropic is such a frame (called "CMB frame").

However, we are not on CMB frame (e.g., dipole term of WMAP is nonzero), so we expect anisotropy by lab experiments even CMB frame is the preferred frame.

5. MiniBooNE experiment

MiniBooNE is a short-baseline neutrino oscillation experiment at Fermilab.

$$\nu_{\mu} \xrightarrow{\text{oscillation}} \nu_e + n \rightarrow e^{-} + p$$

$$\bar{\nu}_{\mu} \xrightarrow{\text{oscillation}} \bar{\nu}_e + p \rightarrow e^{+} + n$$

Neutrino mode analysis: MiniBooNE saw the 3.0σ excess at **low energy region**

Antineutrino mode analysis: MiniBooNE saw the 1.4σ excess at **low and high energy region**

MiniBooNE low E ν_e excess

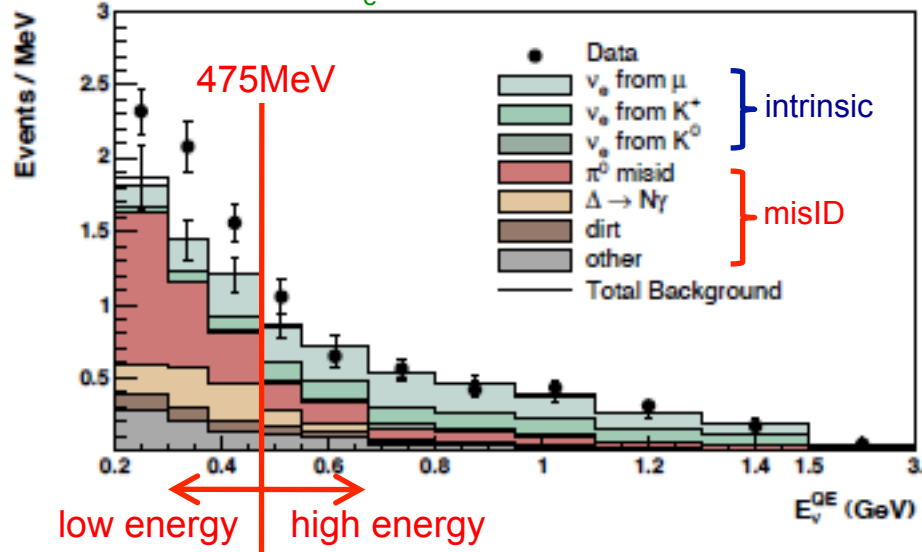

MiniBooNE anti- ν_e excess

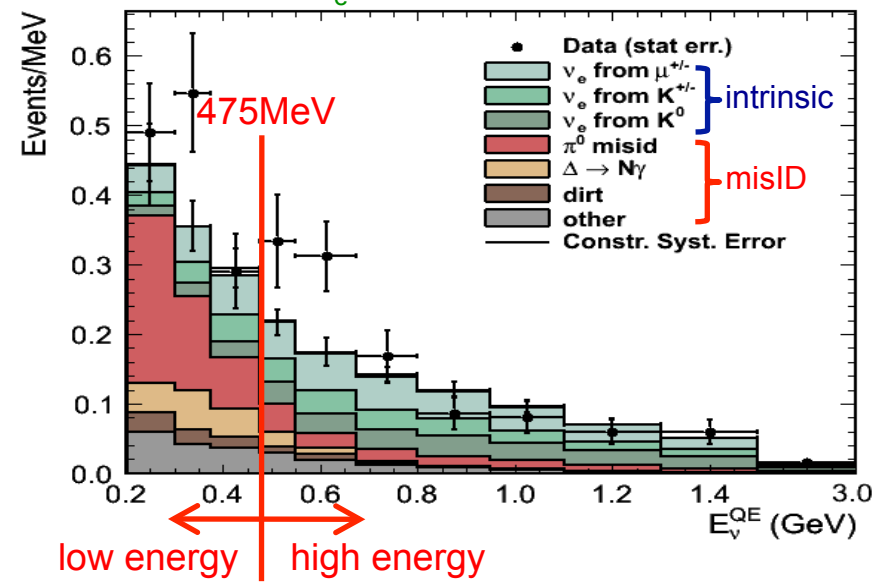

Intrinsic background errors are constraint from MiniBooNE data

Data driven corrections are applied to MisID backgrounds

5. MiniBooNE experiment

MiniBooNE is a short-baseline neutrino oscillation experiment at Fermilab.

$$\nu_{\mu} \xrightarrow{\text{oscillation}} \nu_e + n \rightarrow e^{-} + p$$

$$\bar{\nu}_{\mu} \xrightarrow{\text{oscillation}} \bar{\nu}_e + p \rightarrow e^{+} + n$$

Neutrino mode analysis: MiniBooNE saw the 3.0σ excess at **low energy region**

Antineutrino mode analysis: MiniBooNE saw the 1.4σ excess at **low and high energy region**

MiniBooNE low E ν_e excess

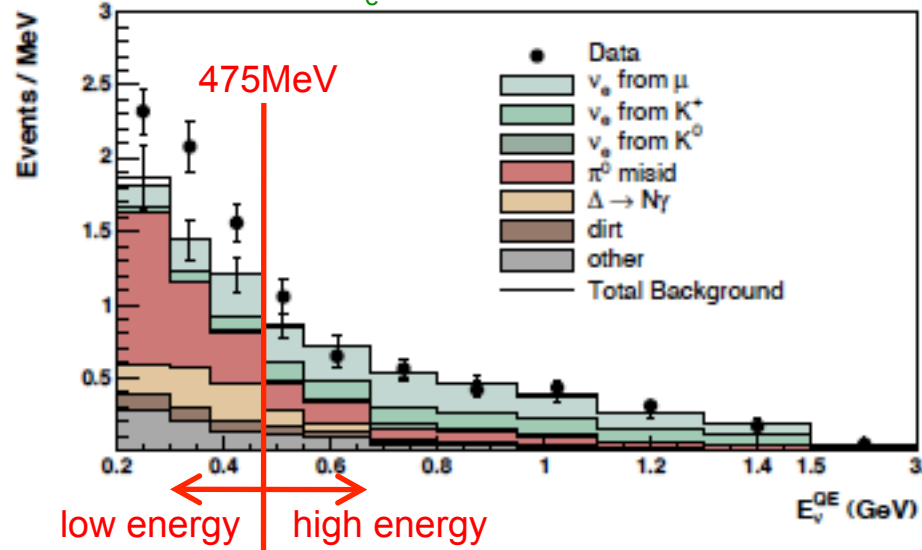

MiniBooNE anti- ν_e excess

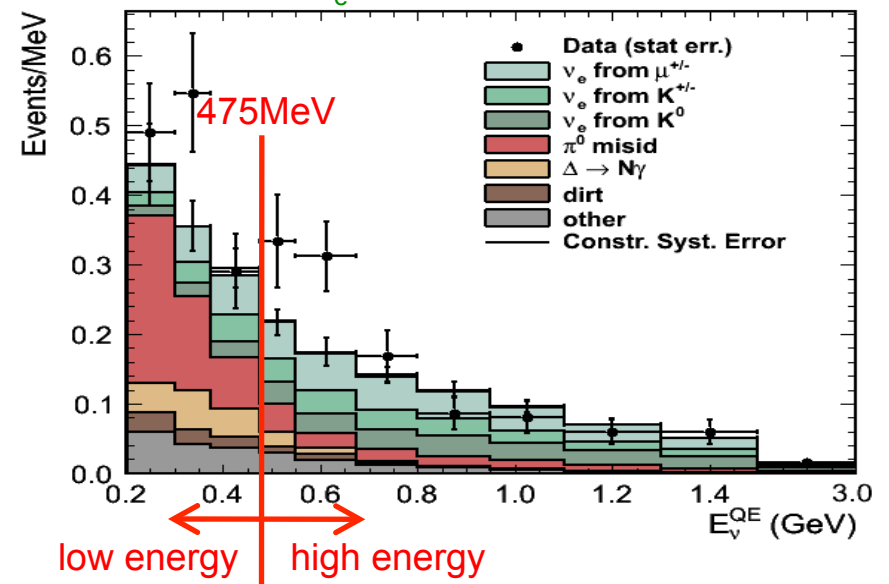

These excesses are not predicted by neutrino Standard Model (ν SM), therefore it might sterile neutrino or other new physics, such as Lorentz violation

→ Oscillation candidate events may have sidereal time dependence!



6. Lorentz violation with MiniBooNE

Sidereal variation of neutrino oscillation probability for MiniBooNE (5 parameters)

$$P_{\nu_e \rightarrow \nu_\mu} = \left(\frac{L}{\hbar c} \right)^2 \left| (C)_{e\mu} + (A_s)_{e\mu} \sin w_{\oplus \oplus} T + (A_c)_{e\mu} \cos w_{\oplus \oplus} T + (B_s)_{e\mu} \sin 2w_{\oplus \oplus} T + (B_c)_{e\mu} \cos 2w_{\oplus \oplus} T \right|^2$$

Expression of 5 observables (14 SME parameters)

$$(C)_{e\mu} = (a_L)_{e\mu}^T - N^Z (a_L)_{e\mu}^Z + E \left[-\frac{1}{2} (3 - N^Z N^Z) (c_L)_{e\mu}^{TT} + 2N^Z (c_L)_{e\mu}^{TZ} + \frac{1}{2} (1 - 3N^Z N^Z) (c_L)_{e\mu}^{ZZ} \right]$$

$$(A_s)_{e\mu} = N^Y (a_L)_{e\mu}^X - N^X (a_L)_{e\mu}^Y + E \left[-2N^Y (c_L)_{e\mu}^{TX} + 2N^X (c_L)_{e\mu}^{TY} + 2N^Y N^Z (c_L)_{e\mu}^{XZ} - 2N^X N^Z (c_L)_{e\mu}^{YZ} \right]$$

$$(A_c)_{e\mu} = -N^X (a_L)_{e\mu}^X - N^Y (a_L)_{e\mu}^Y + E \left[2N^X (c_L)_{e\mu}^{TX} + 2N^Y (c_L)_{e\mu}^{TY} - 2N^X N^Z (c_L)_{e\mu}^{XZ} - 2N^Y N^Z (c_L)_{e\mu}^{YZ} \right]$$

$$(B_s)_{e\mu} = E \left[N^X N^Y \left((c_L)_{e\mu}^{XX} - (c_L)_{e\mu}^{YY} \right) - (N^X N^X - N^Y N^Y) (c_L)_{e\mu}^{XY} \right]$$

$$(B_c)_{e\mu} = E \left[-\frac{1}{2} (N^X N^X - N^Y N^Y) \left((c_L)_{e\mu}^{XX} - (c_L)_{e\mu}^{YY} \right) - 2N^X N^Y (c_L)_{e\mu}^{XY} \right]$$

$$\begin{pmatrix} N^X \\ N^Y \\ N^Z \end{pmatrix} = \begin{pmatrix} \cos \chi \sin \theta \cos \phi - \sin \chi \cos \theta \\ \sin \theta \sin \phi \\ -\sin \chi \sin \theta \cos \phi - \cos \chi \cos \theta \end{pmatrix}$$

coordinate dependent direction vector
(depends on the latitude of FNAL, location
of BNB and MiniBooNE detector)

7. Massive Lorentz-violating model

Double Chooz oscillation signal has no sidereal time dependence.

By assuming main source of neutrino oscillation is neutrino mass, we can study perturbation terms to find secondary effect to cause oscillations.

massive neutrino oscillation Lorentz violating neutrino oscillation

$$P(\bar{\nu}_e \rightarrow \bar{\nu}_e) = P^0(\bar{\nu}_e \rightarrow \bar{\nu}_e) + P^1(\bar{\nu}_e \rightarrow \bar{\nu}_e) + P^2(\bar{\nu}_e \rightarrow \bar{\nu}_e) + \dots$$

In this way, we can access to different types of Lorentz violation

7. Anomalous energy spectrum

Sidereal variation is one of many predicted phenomena of Lorentz violating neutrino oscillations.

Lorentz violation predicts unexpected energy dependence of neutrino oscillations from standard neutrino mass oscillations.

Effective Hamiltonian for neutrino oscillation

$$h_{eff} = \frac{m^2}{2E} + a + cE + \dots$$

massive neutrino oscillation

Lorentz violating neutrino oscillation

This is very useful to differentiate 2 effects:

- massive neutrino oscillation
- sidereal time independent Lorentz violating neutrino oscillation

Double Chooz released its energy spectrum (with full error matrix). We use this to test time independent Lorentz violating neutrino oscillation.

7. Double Chooz spectrum fit

Neutrino-Antineutrino oscillation

- Most of neutrino-neutrino oscillation channels are constraint from past analyses
- Here, we focus to test neutrino-antineutrino oscillation

ex) anti- $\nu_e \rightarrow \nu_e$ oscillation fit with Double Chooz data

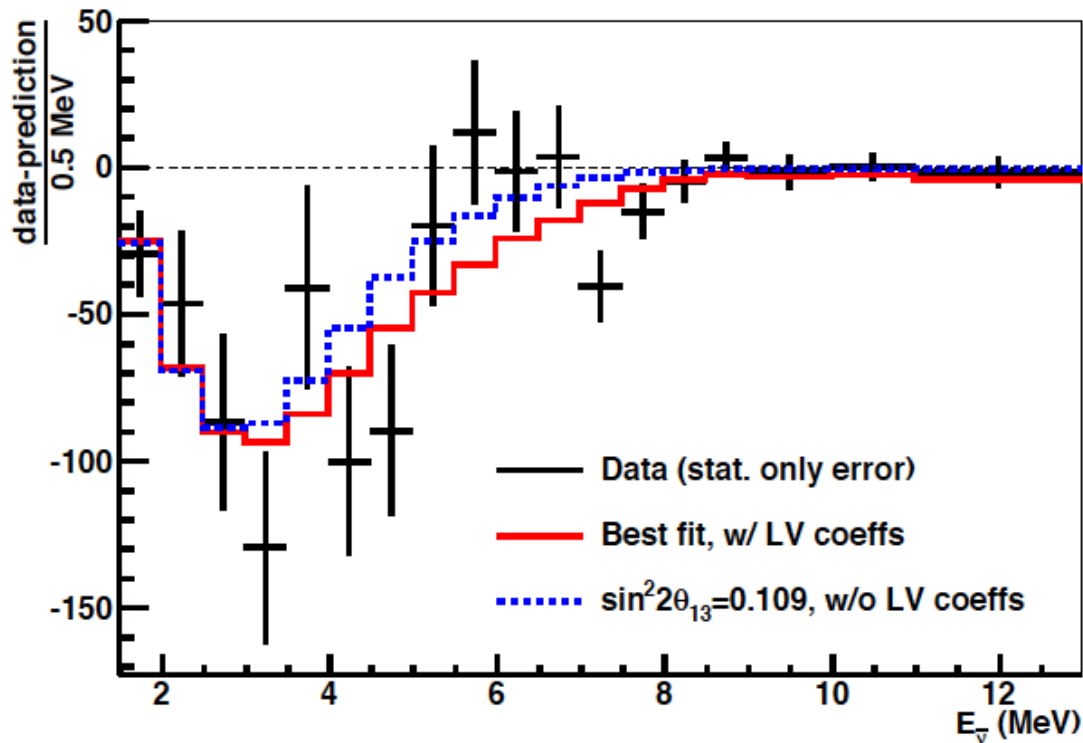

These fits provide first limits on neutrino-antineutrino time independent Lorentz violating coefficients



8. Superluminal neutrinos

OPERA

$$\begin{aligned} v(\text{neutrino}) &= c + (2.37 \pm 0.32) \times 10^{-5} c \\ &= c + (16 \pm 2) \times 10^3 \text{ mph} \end{aligned}$$

It is fascinating result, but...

- time of flight is kinematic test (less sensitive than neutrino oscillations)
- no indication of Lorentz violation from any neutrino oscillation experiments
- superluminal neutrino is unstable (vacuum Cherenkov radiation) [ArXiv:1109.6562](#)
- pion phase space is limited to create such neutrinos [ArXiv:1109.6630](#)
- SN1987A neutrinos provide severe limit to superluminal neutrinos [PRL58\(1987\)1490](#)
- etc...

It is very difficult to interpret superluminal neutrinos at OPERA by Lorentz violation within field theory approach.

7. Sterile neutrino oscillation

